

See discussions, stats, and author profiles for this publication at: <https://www.researchgate.net/publication/325929650>

# Smart Third Umpire Decision Assisting System Using PLC

Conference Paper · November 2015

---

CITATIONS

0

READS

9

1 author:



Vinesh Hanumantharayappa

Darmstadt University of Applied Sciences

1 PUBLICATION 0 CITATIONS

SEE PROFILE

Some of the authors of this publication are also working on these related projects:



Smart Third Umpire Decision Assisting System Using PLC [View project](#)

# Smart Third Umpire Decision Assisting System Using PLC

<sup>[1]</sup> Vinesh C.H, <sup>[2]</sup> Sujatha B.M  
<sup>[1][2]</sup> Acharya Institute of Technology  
<sup>[1]</sup> vinu5130@gmail.com, <sup>[2]</sup> sujathabm2005@gmail.com

**Abstract**— Cricket, a world renowned game has several flaws when it comes to the decisions made by a Third Umpire. Especially in crucial decisions regarding Out/Not Out; his decision has to be accurate and quick. But in few cases he fails to deliver it as he is expected to. Therefore it is essential to make use of technology to eliminate this drawback in the game. Hence in this paper we propose a Smart Third Umpire Decision Assisting System (STUDAS) to overcome this flaw using Programmable Logic Controller (PLC) as well as Supervisory Control and Data Acquisition (SCADA). This system primarily aims to implement event detection and decision making algorithm so as to make the game of cricket much fairer and swifter.

**Index Terms**— Cricket, PLC, Run Out, SCADA, Third Umpire.

## I. INTRODUCTION

In the sport of cricket, technology has played a crucial role in making it a fair game. Several new technologies in the recent times like *HAWK EYE* for LBW detection as well as *SNICKO METER* to detect edging of the ball with the bat have made this game a fair one. In this regard there are no such advancements in the recent times for the case of Run out, except for usage of cameras with high zooming & slow motion recording capabilities. The existing system where a run out is decided by a third umpire using the video clippings of the event has failed to produce accurate results in many cases as well as the time taken by the Third Umpire to analyze the clipping and come to conclusion has been both a time and accuracy issue. According to the rules of ICC, the time to be taken to decide a run out is 30 seconds. But in most of the cases it takes a lot more time than the time mentioned in the rule. Hence by this system, we are able to overcome this drawback in the game of cricket which is one of the major issues of time constraints as well as accuracy. In the past decades, various systems/models have been proposed to improve the umpiring decisions. Contradictory to the past work on the designs of umpiring algorithms, this is a dynamic smart umpiring algorithmic circuitry that could provide accurate results and minimize delay which saves the precious time. The existing methodology wherein video cameras are used in decision making process is unable to give accurate results since there is a high probability of human error where the umpire may perceive the data/video clipping wrongly. To tackle the latter problem, slow---mo cameras can be put into force. But the main issue with slow-mo cameras is that, they are very expensive. A study on the proposed system is presented, and a series of simulation experiments are

conducted to verify the analytic results and to show the Capability of the proposed system. The main objective of the system is to propose a dynamic smart accurate umpiring algorithm circuitry to improve the time constraints as well as precision in run out decision making.



**Fig. 1: Third Umpire**

To achieve this, PLC and SCADA has been made use in the system. The PLC (Programmable Logic Controller) which is widely used in industrial and automation applications does the calculations required for the system whereas the SCADA (Supervisory Control and Data Acquisition) is made use to develop HMI (Human Machine Interface).

**Contribution:** In this paper, a new approach to assist a third umpire's decision in cricket pertaining to Run Out, using PLC and SCADA is proposed. The approach is simple, based on event detection.

**Organization:** Section I gives a brief introduction of problem statement behind this system. The existing proposed systems are described in section II. Background of PLC & SCADA is explained in Section III. Section IV

describes the proposed system working and Section V speaks about Conclusion & Future Work.

## II. RELATED WORK

Shashank Yeole *et al.* has put forth a model [1] in which MATLAB tool is made use to extract frames of video feeds from cameras focusing wickets and crease. The decision is made by monitoring the disturbed frame of wicket camera feed and the corresponding frame of the same time from the crease camera. This system reduced the time taken to decide a run out by 88% when compare to time taken by human eye calculation. Dr. Tariq Mahmood *et al.* in their journal [2] proposes a model similar to the one proposed by Shashank Yeole [1], where it involves extraction of frames from the video feeds and converting them into gray scale image so as to apply certain algorithm and decide a Run out case. But the drawback of this system is that it needs 4 cameras placed at ground level focusing the wicket as well as crease which is quiet impractical. P. Ashok Kumar [3] has put forth a model to detect a run out by using the data acquired from the sensors placed inside batsman/bowler shoes, bat and ball. All the data collected from different sensors are analyzed using certain algorithm to come to a conclusion in a Run out scenario.

Wazir Zada Khan *et al.* have proposed a technique to detect the over step No Ball [4]. The technique is to obtain coordinates of sensors placed near stumps, crease centre and bowlers shoe and then applying a mathematical formula to find out a angle of the triangle made at the point of sensor at crease centre. If the angle at that point is found to be more than  $90^\circ$ , then it is concluded as a No Ball and Vice versa. Nikhil Batra *et al.* have proposed a model [5] to identify over step No Ball, which is much advance and complex than the one proposed by Wazir Zada Khan [4]. The top view image of the pitch area is taken at the moment the bowler keeps his leg on the ground during ball delivery. Then the system applies Canny Edge detection and Hough Line Transform algorithm to the captured image. After this, the same technique used in [4] to find the angle is applied and the result is concluded similarly. Hao Tang *et al.* in their paper [6] propose a novel approach for detecting highlights in sports videos using easy-to-extract low-level visual features such as the color histogram (CH) or Histogram of Oriented Gradients (HOG). Xiaolong Li *et al.* have put forth a technology in their journal [7] which makes an effort to make use one of the wireless technologies ZigBee to Programmable logic controller (PLC) so that the remote field devices can be controlled without wiring. This technology can be made use in our system to obtain data from load cell and the contact switches to the PLC placed at a distance wirelessly.

## III. BACKGROUND

### A. PLC



Fig. 2: Siemens S7-300 PLC

PLCs are a type of digital computers predominantly used in industrial automation. They are most preferred on the factory floors since they are flexible and robust. Usually small PLCs have fixed number of Inputs and Outputs. Few of them are even provided with expansion if they fall short of I/O. Software to program a PLC is installed in PCs and the program is dumped into the PLC using serial cables like Ethernet or MPI cables. In most of the cases, PLCs can be reprogrammed according to the changes required by the user. The PLC model used in our system is Siemens S7-300 which is specially designed for automotive and packaging industries. It hosts a 2DP CPU (315-2AH14-0AB0) that has 128KB RAM. It is equipped with an Analog Input module (AI 331-1KF01-0AB0), Digital Input module (DI 6ES7321-1BH02-0AA0), Analog Output module (AO 322-5HB01-0AB0), Digital Output module (DO 322-1BH01-0AA0) and a Communication Port (CP 343-1-LEAN-343-1CX10-0XE0).

### B. SCADA

SCADA (Supervisory Control and Data Acquisition) is a computer application used to monitor and control the systems at supervisory level. It is usually made use to detect and correct problems and measure trends over time in complex industrial processes such as oil and gas refineries, water treatment plants, automotive production lane etc. Other tasks of a SCADA system is to create logs and report about systems present and past state from distance [7]. It can also be used to set up alarms in systems to indicate the user when a pre defined condition is met by the system. In general SCADA plays an important role in Human Machine Interface.

### C. Load Cell

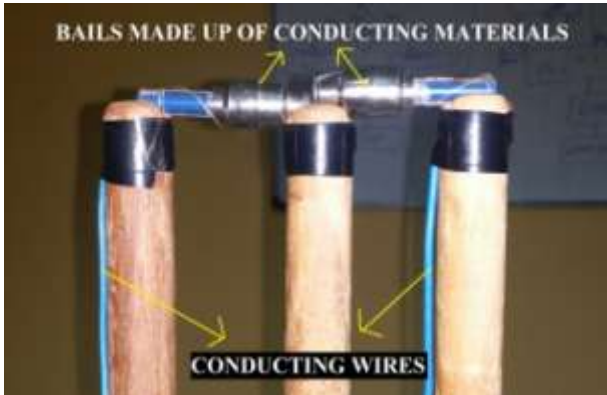

Fig. 3: Load Cell

The load cells are often used inside weighing devices and are the main functional units in them. Here in STUDAS, CZL 601 Load cell is made use. This Load cell is a Strain gauge load cell where a strain gauge acts as a transducer in converting the mechanical energy i.e. weight into electrical energy. Inside the load cell, 4 strain gauges are placed at certain points in the form of a Wheatstone network. The change in resistance of the strain gauge will be directly proportional to the electrical output of the cell. This output value is used to determine the weight applied on it. Because

of its rigidity, they are widely used in industrial applications.

**D. Contact Switch**



**Fig. 4: Contact Switch arrangement in STUDAS**

The contact switch arrangement used in STUDAS is shown in Fig.4. This arrangement is made use to detect the detachment of bails from stumps. As show in Fig. 4, two conducting wires have their ends connected to the contact surfaces (a conducting surface) on the top of the rightmost and the leftmost stumps. These two contact surfaces are connected by bails which are made up of conducting materials. And thus forms a closed loop for current to pass through. Whenever the bails go up, the circuit breaks and the moment this happens, PLC notes the time at which the bails went up and further uses it in the decision making algorithm.

**IV. PROPOSED SYSTEM**

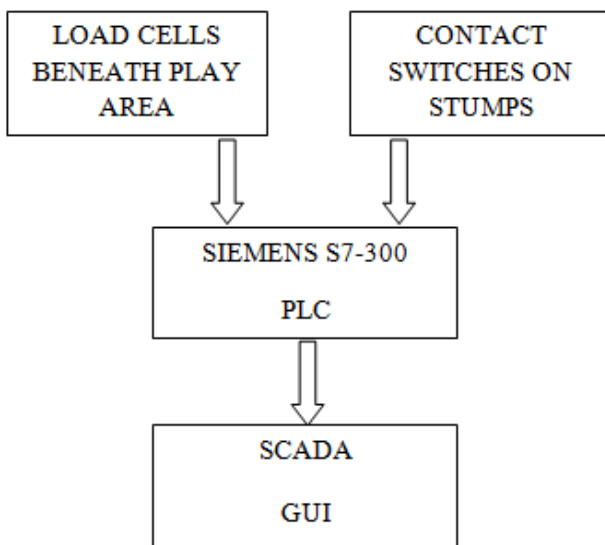

**Fig. 5: Basic Block Diagram of Proposed System**

The main criteria in decision making inside the system is to find which among the two events occurred first i.e. Bails detachment or Crease touch. Both the load cell and the contact switch arrangement have been given as input to Analog input module and Digital input module of PLC respectively. As soon as a load such as bat or the batsman’s leg is on the load cell, it produces a small amount of voltage in terms of mV and it reaches the AI. Similarly when the bails go up, the contact switch arrangement which was a closed circuit becomes an open circuit. This change is noted down by the PLC. Next the ladder logic does the decision based on the time at which these two events have occurred.

The load cells (CZL601) placed beneath the play area is of the range 0-10 kg. When a load/weight is applied on these sensors, they produce a voltage up to 500mV which is fed as input to the PLC through the Analog Input module i.e. AI. Bails here, act as a contact switch between the extreme end wickets as they are made up of conducting material. A wire which runs along the length of the two extreme end stumps connects the contacts which are on the top of stumps, to the PLC. So in a whole, a closed circuit is formed and the two ends of the circuit are connected to the Digital input module i.e. DI. This module detects any breakage in circuit i.e. whenever bails get detached, the circuit opens and will be noted by the PLC. The SCADA

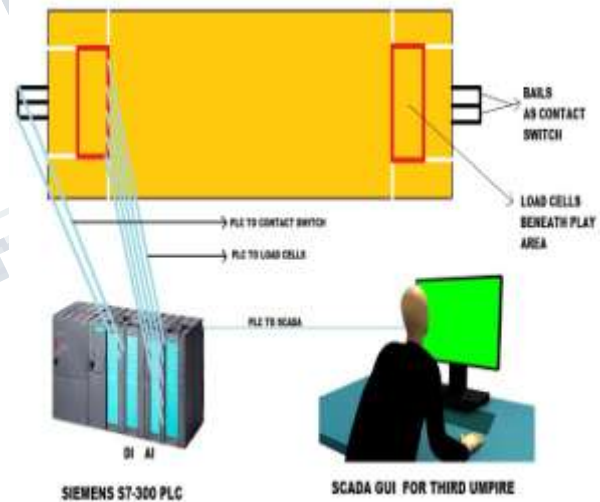

**Fig. 6: Graphical Overview of STUDAS** (Supervisory Control and Data Acquisition) screen developed, act as a Human Machine Interface for the Third Umpire. He is first notified with a color change in the play area region in the first window to indicate which side of the pitch the run out has occurred. Next window shows which all sensors have been activated i.e. on which all sensors the weight has been applied. The next window provides an option/button for the umpire to ask the system’s decision. The result window is developed such that it shows Red if out and Green if not. The third umpire can also view the trend window i.e. a SCADA screen which graphically shows which event occurred at first place viz. load on the



load cell or detachment of bail from stumps. If the load cell graph line has gone high after the bail graph line, then the result would have appeared as Not Out or if the graph line of bails has gone up before the graph line of load cells then the decision would be out. This can be used to cross verify the result. The graphical overview of STUDAS is shown in the Figure 6.

**A. Ladder Logic**

The ladder logic of this system was simulated and tested on Seimens Simatic S7 Manager v5.5. Among the blocks used in the ladder logic, FC108 is a scaling block which was developed to scale the input from the load cells which is in terms of voltage to a user defined unit, for example 0-100. The output of FC108 block follows the formula mentioned below. Using this formula a user can choose the range of output one desires.

$$SENSOR\_OUT = \frac{PIW\_x \times (HI\_LIM - LOW\_LIM)}{27648} + LOW\_LIM$$

Where HI\_LIM = 100 & LOW\_LIM = 0 (Here). PIW\_x is a register to which the varying sensor output value is stored.

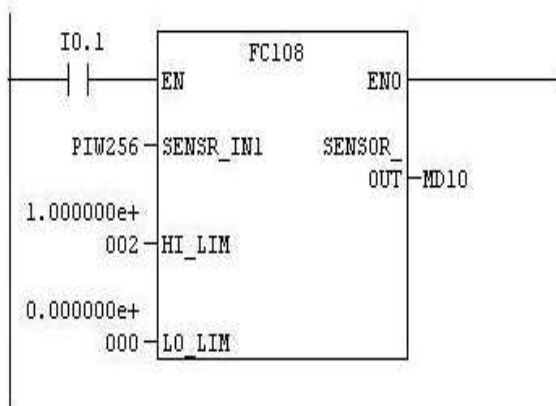

**Fig. 7: FC 108 Block**

The primary goal in implementing FC108 block as shown in the Fig. 7 is to scale down the output from load cells to any range between HI\_LIM and LOW\_LIM. The output SENSOR\_OUT is directed to a memory location MD10 for further processing. Apart from processing the outputs of load cells, the system also needs to monitor the contact switch outputs. Hence the ladder logic to perform this action consists of an On Delay Timer and Move blocks as shown in the Figure 8.

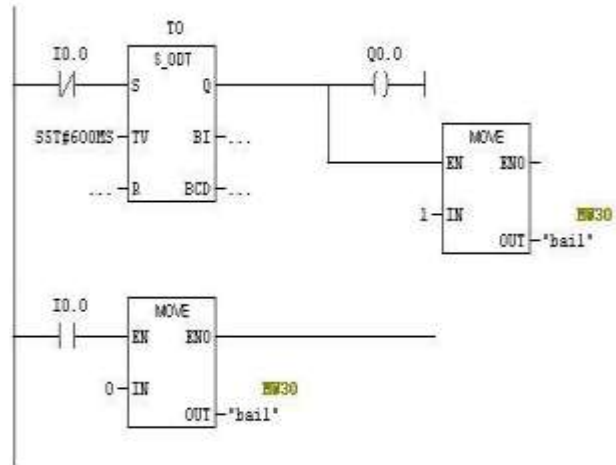

**Fig. 8: Contact Switch's Ladder logic**

As in the Fig. 8 the On Delay Timer (S\_ODT) is used in the ladder logic to nullify the delays in the system. Since contact switch arrangements output is always high when bails are intact with the stumps, the output coil Q0.0 will be generally high. Only when the switch goes off i.e. bails detach from the stumps, the coil Q0.0 goes low. The state of Q0.0 is compared with the load cells output in the decision making algorithm.

**V. RESULTS & DISCUSSIONS**

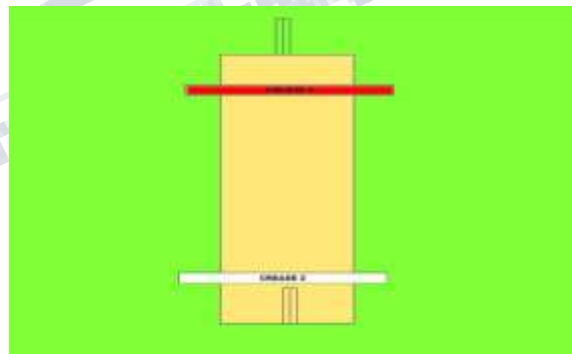

**Fig. 9: SCADA Screen 1**

The Fig. 9 shown above is the first SCADA screen which will be appearing on the Third umpire's monitor. Soon after a run out scenario in any part of the pitch the third umpire is notified by the color change in the crease button i.e. color change from white to red as shown above. This makes it easy for the umpire to know which part of the pitch the run out occurred so that he chooses to see which all sensors are activated in that play area. The white color crease button changes to red color whenever there is a load more than the threshold defined in the comparator. This screen notifies the third umpire that which load cell among the load cells beneath the play area is activated. This change is shown by the color change in the sensor button as shown. The white color sensor button will be changed to red color as shown in the Fig.10. By clicking the sensor button whose color

change has occurred, the umpire will be led to another screen which is the result window where the umpire asks the system for result. In the result window as shown in the Fig. 11 and Fig. 12, the umpire clicks the 'Result' button to know the systems decision. As said before, the system identifies which event occurred first and gives out the result.

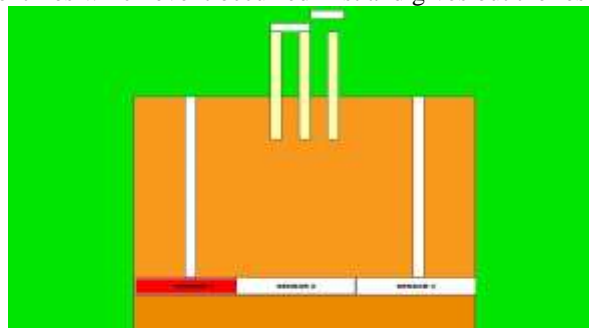

Fig. 10: SCADA Screen 2

The window shown in Fig. 11 appears when the decision given by the system is Not out i.e. the not out button appears in green color, indicating that the batsmen is not out as the load cells have been activated first and then the bails have gone up.

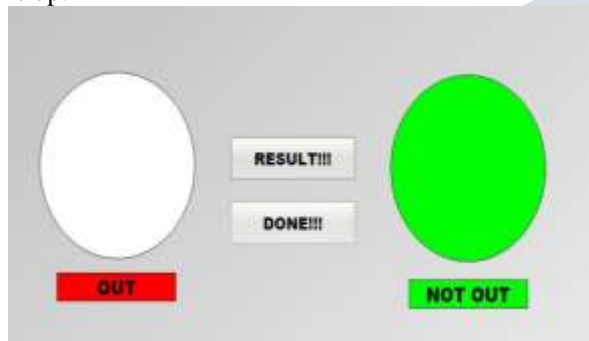

Fig. 11: SCADA Screen 3

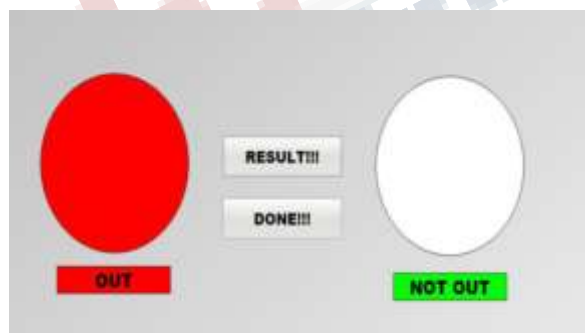

Fig. 12: SCADA Screen 4

The window in Fig.12 appears when the case is out i.e. out button appears in red color, indicating that the batsmen is out as the load cells have been activated after the bails went up. As it can be seen clearly from the SCADA Trend window/graph in Fig. 13, that the black colored graph line which represents bails, has gone high after the red colored

graph line representing load sensors, which implies Not Out & vice versa for Out case. This window can be used to cross verify the systems decision.

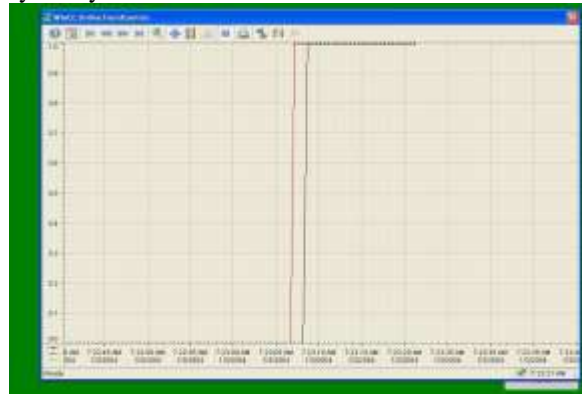

Fig. 13: SCADA Trend Window

It is evident that the third umpire using the existing video analysis system takes an average of 50-70 seconds to decide a Run out. In few unfortunate cases the umpire has also given unfair decisions even after taking time. When this system was tested it gave out results within 10 seconds with almost cent percent accuracy which easily says the system eliminates the time and accuracy issues present in the existing video analysis system

## VI. CONCLUSION & FUTURE WORK

The two parameters i.e. Time & Accuracy, which were our major concern before implementing the system was successfully optimized by making use of PLC as well as SCADA. Hence one among many flaws which the game of cricket has is eliminated by this system. Henceforth, the decision by a Third umpire can be given within the time limit i.e. 30 seconds as per the ICC law. Not only reducing the time to decide has been reduced but also the degree of accuracy has been increased to almost cent percent.

Further, the same load cells can also be used to detect Overstep No ball using similar but less complex algorithm. This can reduce the time taken by the third umpire during checking whether the delivery is legal or not. Also, other decision assisting systems pertaining to Boundaries and Catches, combined with this system together can work as a single unit as Virtual Third Umpire, eliminating the need of human intervention in decision making process.

## REFERENCES

- [1] Shashank Yeole, Nisheet Sharma, Yogesh Shinde and Sufiyan Shaikh: "Use of Image Processing Techniques for Making Run out Decision in Cricket," International Journal Of Engineering and Computer Science ISSN:2319-7242 Volume 3 Issue 5 may, pp. 6212-6215, 2014

- [2] Dr. Tariq Mahmood, Syed Obaid Ahmed, Muhammad Hadi, Swaleh Syed Hassan Nayyer, "A-Eye: Automating the Role of the Third Umpire in the Game of Cricket," IEEE Journal, 2011.
  
- [3] P. Ashok Kumar: "Automated Decisions in Aware Cricket Ground: A Proposal," International Journal of Information and Education Technology, Vol. 2, No. 3, June 2012.
  
- [4] Wazir Zada Khan, Mohammed Y, Aalsalem and Quratul Ain Arshad: "The Aware Cricket Ground," IJCSI International Journal of Computer Science Issues, Vol. 8, Issue 4, No 2, July 2011 ISSN (Online): 1694-0814.
  
- [5] Nikhil Batra, Harsh Gupta, Nakul Yadav, Anshika Gupta and Amita Yadav: "Implementation of Augmented Reality in Cricket for Ball Tracking and Automated Decision Making for No Ball," International Conference on Advances in Computing, Communications and Informatics (ICACCI), 2014.
  
- [6] Hao Tang, Vivek Kwatra, Mehmet Emre Sargin, Ullas Gargi: "Detecting Highlights In Sports Videos: Cricket as a test case," Google INC, Mountain View, C.A.
  
- [7] Xiaolong Li, Sairam Munigala and Qing-An Zeng: "Design and Implementation of a Wireless Programmable Logic Controller System," International Conference on Electrical and Control Engineering, 2010.