



Sixth Semester B.E. Degree Examination, June/July 2024 Power System Analysis – II

Time: 3 hrs.

Max. Marks: 100

Note: Answer any FIVE full questions, choosing ONE full question from each module.

Module-1

- 1 a. Define the following terms in network topology with example:
- (i) Tree
 - (ii) Basic cut-set
 - (iii) Bus Incidence matrix. (06 Marks)
- b. Consider an oriented graph shown below in Fig. Q1 (b). Choose branches d, e and f as twigs. Construct the fundamental cut set matrix and Tie set matrix.

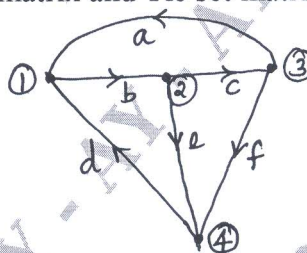

Fig. Q1 (b) (06 Marks)

- c. A power system consists of four buses. The generators are connected at buses 1 and 3. The transmission lines are connected between buses 1 – 2, 1 – 4, 2 – 3 and 3 – 4 which have reactances of $j0.25$, $j0.5$, $j0.4$ and $j0.1$ respectively. Develop the bus admittance matrix by inspection method. Choose bus – 1 as the reference. (08 Marks)

OR

- 2 a. With usual notations, derive Y_{BUS} by singular transformation. (06 Marks)
- b. Obtain Y_{BUS} by singular transformation method for the power system network having the following data : Take bus – 4 as reference bus.

| | | | | | |
|------------------|-------|-------|-------|-------|-------|
| Element No. | 1 | 2 | 3 | 4 | 5 |
| Bus code (p – q) | 1 – 2 | 2 – 3 | 3 – 4 | 1 – 4 | 2 – 4 |
| Admittance (pu) | 2 | 1.5 | 3 | 2.5 | 4 |

(06 Marks)

- c. For the power system shown in Fig. Q2 (c), obtain Y_{BUS} by singular transformation.

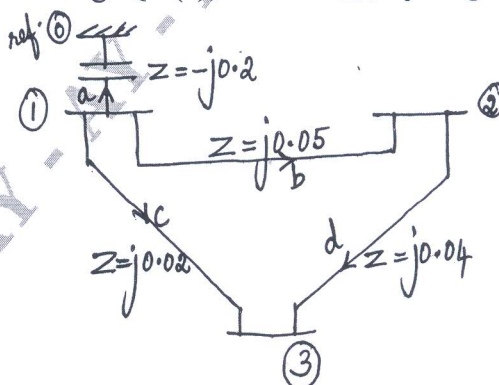

Fig. Q2 (c) (08 Marks)
1 of 3

Important Note : 1. On completing your answers, compulsorily draw diagonal cross lines on the remaining blank pages.
2. Any revealing of identification, appeal to evaluator and /or equations written eg, 42+8 = 50, will be treated as malpractice.

Module-2

- 3 a. What is load flow study? Derive the load flow equations used in load flow study. (08 Marks)
 b. For the power system network shown in Fig. Q3 (b), the line reactances are in pu. The bus data are shown in Table Q3 (b). Determine the voltages at bus-2 and bus-3 at the end first iteration using Gauss-Seidel method. Take acceleration factor $\alpha = 1.6$. (12 Marks)

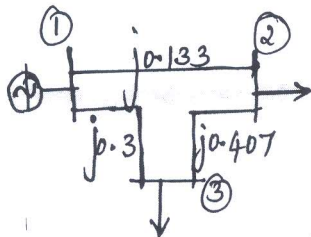

Fig. Q3 (b)

| Bus No. | Type | Generation | | Load | | Bus voltage | |
|---------|-------|------------|-------|-------|-------|-------------|----------|
| | | P_G | Q_G | P_L | Q_L | $ V $ | δ |
| 1 | Slack | - | - | - | - | 1.05 | - |
| 2 | PQ | 0 | 0 | 0.7 | 0.8 | - | - |
| 3 | PQ | 0 | 0 | 0.5 | 0.2 | - | - |

Table Q3 (b)

OR

- 4 a. Explain the algorithm for Gauss-Seidel method to obtain the load flow solution of a power system network. (10 Marks)
 b. For a 4-bus power system network shown in Fig. Q4 (b), the real and reactive power and the bus data is given in Table Q4 (b). Assuming a flat voltage start compute the unknown variables in all the buses other than the slack bus at the end of first iteration by Gauss-Seidel method. The line data is impedance in pu. (10 Marks)

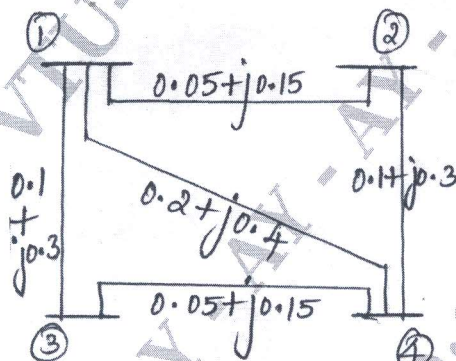

Fig. Q4 (b)

| Bus No. | P_i (pu) | Q_i (pu) | V_i (pu) |
|---------|------------|------------|-----------------------|
| 1 | - | - | $1.05 \angle 0^\circ$ |
| 2 | 0.5 | -0.2 | - |
| 3 | -1.0 | 0.5 | - |
| 4 | 0.3 | -0.1 | - |

Table Q4 (b)

Module-3

- 5 a. Compare Gauss-Seidel and Newton-Raphson method of load flow solution with respect to various parameters. (08 Marks)
 b. List out the assumptions of FDLF method and derive the expressions for the Jacobian elements of FDLF method of load flow solution. (12 Marks)

OR

- 6 a. Explain the algorithm of Newton-Raphson method for the load flow solution of a power system network. (10 Marks)
 b. In a two bus power system network shown in Fig. Q6 (b), bus-1 is a slack bus with $V_1 = 1 \angle 0^\circ$ pu and bus-2 is a load bus with $P_2 = 100$ MW ; $Q_2 = 50$ MVar. The line impedance is $(0.12 + j0.16)$ pu on a base of 100 MVA. Using NR method of load flow solution, compute the elements of the Jacobian matrix. (10 Marks)

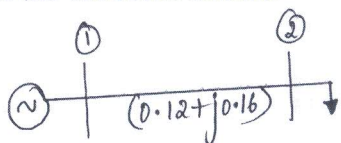

Fig. Q6 (b)

Module-4

- 7 a. Draw and explain the following performance curves related to thermal plants:
- Input and output curve
 - Heat-rate curve.
- (04 Marks)
- b. Derive the expressions for transmission loss co-efficient in terms of plant generation capacities for two units delivering a load. (08 Marks)
- c. The fuel cost function in Rs/hr for three thermal plants are given by,
- $$F_1 = 350 + 7.2 P_{G1} + 0.004 P_{G1}^2 \text{ Rs/hr}$$
- $$F_2 = 500 + 7.3 P_{G2} + 0.0025 P_{G2}^2 \text{ Rs/hr}$$
- $$F_3 = 600 + 6.74 P_{G3} + 0.003 P_{G3}^2 \text{ Rs/hr}$$
- Determine the optimal generation scheduling neglecting the losses for a load of 450 MW. Also, calculate the cost of production of 450 MW for the obtained schedule. (08 Marks)

OR

- 8 a. Obtain the Economic generation scheduling for a system by considering transmission losses and neglecting generator limits. (06 Marks)
- b. In a system with two plants, the incremental fuel costs are given by,
- $$\frac{dF_1}{dP_{G1}} = 0.01P_{G1} + 20 \text{ Rs/MWhr}; \quad \frac{dF_2}{dP_{G2}} = 0.015P_{G2} + 22.5 \text{ Rs/MWhr}$$
- The system is running under optimal schedule with $P_{G1} = P_{G2} = 100 \text{ MW}$. If $\frac{\partial P_L}{\partial P_{G2}} = 0.2$.
- Find $\frac{\partial P_L}{\partial P_{G1}}$ and plant penalty factors. (06 Marks)
- c. With usual notations and formulas, explain the flowchart of forward dynamic programming (DP) approach of unit commitment solution. (08 Marks)

Module-5

- 9 a. Explain the modification of Z_{bus} in Z_{bus} building algorithm when a branch is added to the partial network without mutual coupling. (10 Marks)
- b. Explain the numerical solution of swing equation by point by point method. (10 Marks)

OR

- 10 a. Construct the bus impedance matrix Z_{bus} by bus building algorithm for the system shown in Fig. Q10 (a). All impedances are in pu. Take ground node $\textcircled{0}$ as the reference node. Add the elements in the order bus 1 to ref.bus, bus 2 to ref.bus, bus 3 to bus 1, bus 2 and bus 1, bus 3 and bus 2. (10 Marks)

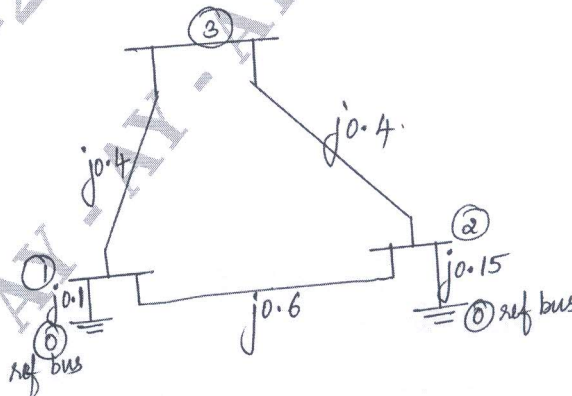

Fig. Q10 (a)

- b. Explain the numerical solution of swing equation by Runge-Kutta method. (10 Marks)
