

CBCS SCHEME



USN

--	--	--	--	--	--	--	--	--	--

18ARC42

Fourth Semester B.Arch. Degree Examination, Jan./Feb. 2023 Materials and Methods in Building Construction – IV

Time: 4 hrs.

Max. Marks: 100

- Note:** 1. Answer any FIVE full questions, choosing ONE full question from each module.
2. Use suitable scale to draft.
3. Support answers with neat sketches where necessary.

Module-1

- 1 a. Below is a part plan of a column beam plan of a framed building, 2 storey high.

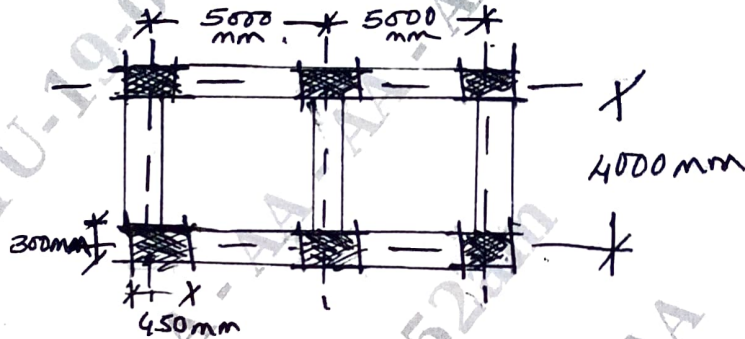

Fig.Q1(a)

Draw a section and one junction detail showing all reinforcement details in a suitable scale. Assume appropriate depth of the slab and beams, column size is 450 mm × 300 mm.

- b. Explain the load transfer path of a moment frame. (15 Marks)

(05 Marks)

OR

- 2 a. Briefly discuss the different types of flat slab. Use suitable sketches to support the discussion. (04 Marks)
b. Draw a flat slab of span 16 m × 20 m. Show all reinforcement details using a plan and section in a suitable scale. (16 Marks)

Module-2

- 3 Discuss the principles and methods of construction of a filler slab using examples and sketches. (20 Marks)

OR

- 4 The entrance lobby of an office building of span 10 m × 14 m has a waffle slab. Draw to a suitable scale.
a. Plan showing column placement (07 Marks)
b. Section showing reinforcement (07 Marks)
c. One detail (06 Marks)

Module-3

- 5 “Steel, is one of the most prevalent construction materials of the century.” Explain the types, properties, advantages and uses of steel in the construction industry. (20 Marks)

Important Note : 1. On completing your answers, compulsorily draw diagonal cross lines on the remaining blank pages.
2. Any revealing of identification, appeal to evaluator and /or equations written eg, 42+8 = 50, will be treated as malpractice.

OR

- 6 Discuss the methods of assemblage of structural steel sections. Sketch the following connection detail:
- (i) Beam to beam connection
 - (ii) Beam to column connection
- (20 Marks)

Module-4

- 7 It has been proposed to use steel windows of size 1.2×1 m (w \times h) in a hospital building. Draw the following to a suitable scale:
- (i) Elevation
 - (ii) Plan showing the detail of steel sections
 - (iii) 1 detail
- (20 Marks)

OR

- 8 a. What is a rolling shutter? Discuss its various types. (08 Marks)
- b. Discuss the various components of a rolling shutter and demonstrate them using an elevation and section sketch. (12 Marks)

Module-5

- 9 a. Discuss the manufacturing process of aluminum, a building material. (10 Marks)
- b. Draw any two standard aluminum sections in a partition. (10 Marks)

OR

- 10 Draw to a suitable scale plan, elevation and two details of an aluminum horizontally sliding sash window of size $1.8 \text{ m} \times 1.2 \text{ m}$ (W \times H). (20 Marks)
