

USN

--	--	--	--	--	--	--	--	--	--

18CIV14/24

**First/Second Semester B.E. Degree Examination, July/August 2022**  
**Elements of Civil Engineering and Mechanics**

Time: 3 hrs.

Max. Marks: 100

**Note :** 1. Answer any FIVE full questions, choosing ONE full question from each module.  
2. Missing data, if any, may be suitably assumed.

**Module-1**

- 1 a. Explain the role of Civil Engineering in the infrastructure development of the Country. (08 Marks)
- b. State the scope of Civil Engineering in : i) Structural Engineering ii) Geotechnical Engineering iii) Transportation Engineering. (06 Marks)
- c. State and explain Basic Idealization of Mechanics. (06 Marks)

OR

- 2 a. State and explain the effect of Infrastructural facilities on Social – Economic development of a Country. (08 Marks)
- b. State and explain Parallelogram Law of Forces. (04 Marks)
- c. Determine the Resultant force and Position of Resultant force with respect to Point 'O' of the plate shown in Fig. Q2(c) for the system of forces. (08 Marks)

Fig. Q 2(c)

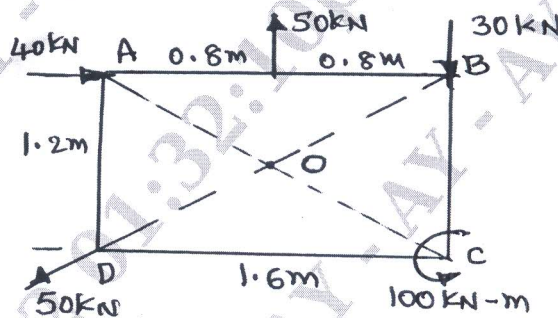

**Module-2**

- 3 a. State and explain Lami's theorem. (04 Marks)
- b. State the Laws of Dry Friction. (04 Marks)
- c. Find tension in string if the system is in Equilibrium shown in Fig. Q3(c). (12 Marks)

Fig. Q 3(c)

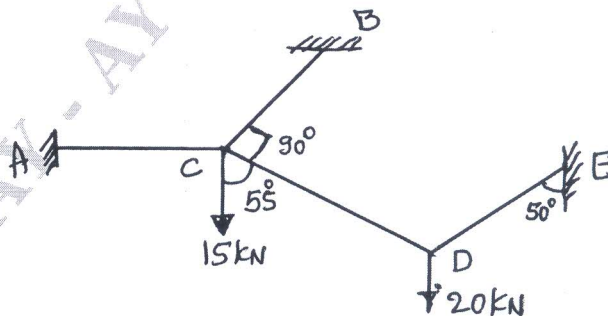

OR

Important Note : 1. On completing your answers, compulsorily draw diagonal cross lines on the remaining blank pages.  
2. Any revealing of identification, appeal to evaluator and /or equations written eg, 42+8 = 50, will be treated as malpractice.

- 4 a. Define i) Coefficient of friction ii) Angle of friction. (04 Marks)  
 b. Find Contact Pressure at surfaces of contact for the system shown in Fig. Q4(b) for two identical cylinders. (06 Marks)

Fig. Q 4(b)

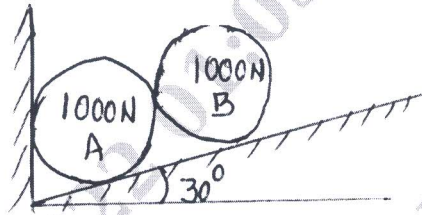

- c. Two Blocks A and B are connected by a horizontal rod and are supported on two rough planes as shown in Fig. Q4(c). The coefficient of friction of block A is 0.25 and for block B is 0.35. Find smallest weight of block A for which equilibrium can exit. If the weight of block B is 1500N. (10 Marks)

Fig. Q 4(c)

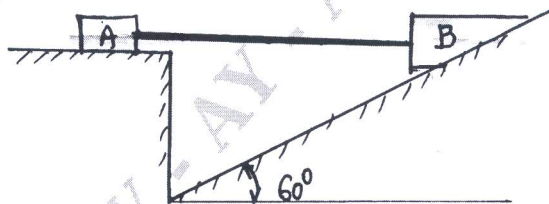

**Module-3**

- 5 a. State and explain different types of loads with neat sketches. (06 Marks)  
 b. State the assumptions made in truss analysis. (04 Marks)  
 c. Determine the support reactions of the overhanging beam shown in Fig. Q5(c). (10 Marks)

Fig. Q 5(c)

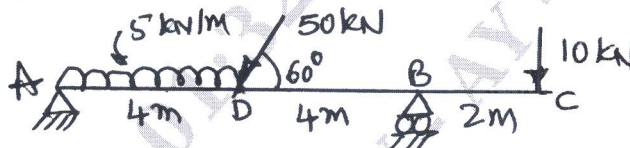

OR

- 6 a. Distinguish between Statically determinate and Indeterminate beams with examples. (06 Marks)  
 b. State and explain different types of supports with neat sketches. (06 Marks)  
 c. Determine the forces in members of the truss shown in Fig. Q6(c) by using method of Joints. (08 Marks)

Fig. Q 6(c)

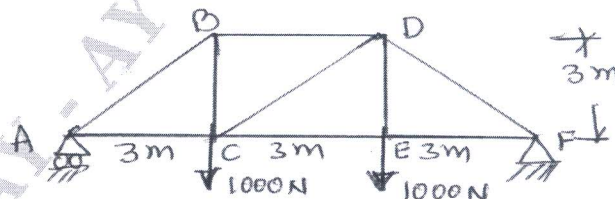

**Module-4**

- 7 a. Define Moment of Inertia , Centroid , Centre of Gravity , Radius of Gyration and Polar Moment of Inertia. (05 Marks)  
 b. State and Prove Parallel Axis theorem. (05 Marks)

- c. Determine the Centroid of shaded area shown in Fig. Q7(c), with respect to 'O'. (10 Marks)

Fig. Q 7(c)

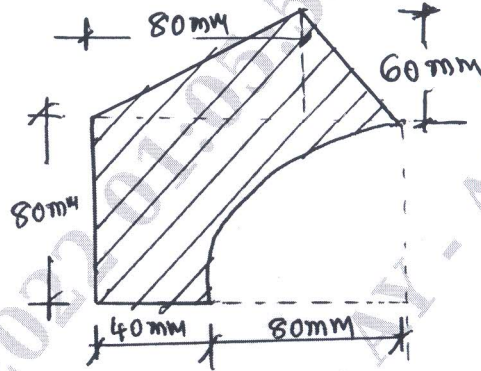

OR

- 8 a. Determine the Centroid of Semicircle about Horizontal diametrical axis. (05 Marks)  
 b. Determine the Moment of Inertia of Triangle about axis passing through Base. (05 Marks)  
 c. Find Radius of Gyration of the area shown in Fig. Q8(c) about Centroidal X - axis. (10 Marks)

Fig. Q 8(c)

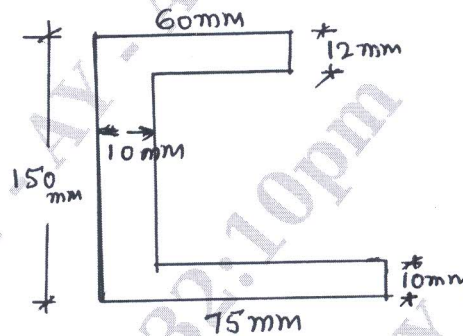
Module-5

- 9 a. Define : i) Displacement ii) Velocity iii) Acceleration iv) Retardation v) Path. (05 Marks)  
 b. State Newton's laws of Motion. (03 Marks)  
 c. A bullet fired upwards at an angle of  $30^\circ$  to the horizontal from top of hill of height 80m and bullet strikes the ground which is 80m lower than the point of projection if the initial velocity of bullet is 100m/sec.  
 Find i) Maximum height the bullet rise above the point of projection.  
 ii) The velocity with which it strikes the ground.  
 iii) Time of flight of bullet. (12 Marks)

OR

- 10 a. Define : i) Trajectory ii) Time of flight iii) Range. (03 Marks)  
 b. Define Super elevation and state the importance of super elevation. (05 Marks)  
 c. A body falling freely under the action of gravity passes two points 20m apart vertically in 0.4 seconds. From what height above the higher point the body starts to fall. Take  $g = 9.8 \text{ m/sec}^2$ . (12 Marks)

\*\*\*\*\*