

USN

--	--	--	--	--	--	--	--	--	--

21CIV14/24

**First/Second Semester B.E. Degree Examination, July/August 2022**  
**Elements of Civil Engineering and Mechanics**

Time: 3 hrs.

Max. Marks: 100

*Note: Answer any FIVE full questions, choosing ONE full question from each module.*

**Module-1**

- Briefly enumerate the scope of following specialization/branches of civil engineering:
    - Structural Engineering
    - Transportation Engineering.
 (10 Marks)
  - Discuss the role of civil engineer in infrastructure development of a country. (05 Marks)
  - Mention the properties and uses of aluminium in construction industry. (05 Marks)

**OR**

- Enlist the qualities of good building stone. (06 Marks)
  - What is glass? List its importance and application. (06 Marks)
  - Discuss the importance and application of smart materials in construction. (08 Marks)

**Module-2**

- Explain 'Principle of Transmissibility' with a neat sketch. (04 Marks)
  - Determine the resultant of four concurrent force system acting on a particle as shown in Fig.Q.3(b). (08 Marks)

Fig.Q.3(b)

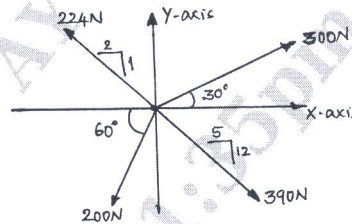

- The Fig.Q.3(c) shows a system of cables in equilibrium under two vertical loads of 300N and 500N acting at points B and C respectively. Determine the forces developed in all the cables. (08 Marks)

Fig.Q.3(c)

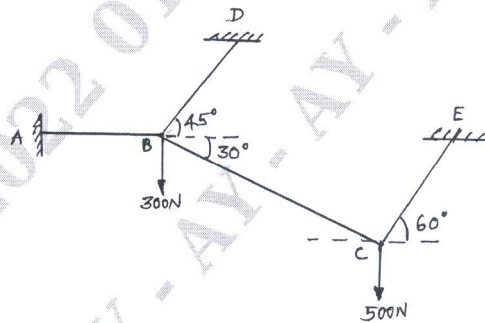

**OR**

- Determine the magnitude, direction and position of the resultant of the force system shown in Fig.Q.4(a). (10 Marks)

Fig.Q.4(a)

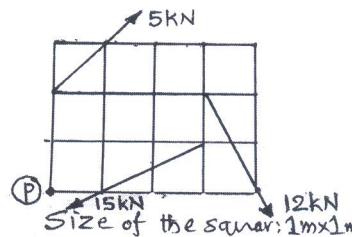

Important Note : 1. On completing your answers, compulsorily draw diagonal cross lines on the remaining blank pages.  
2. Any revealing of identification, appeal to evaluator and /or equations written eg, 42+8 = 50, will be treated as malpractice.

- b. A block of mass 20kg placed on an inclined plane as shown in Fig.Q.4(b) is subjected to a force P acting parallel to the plane. The plane is inclined at an angle  $30^\circ$  to the horizontal with coefficient of friction being 0.24. determine the magnitude of P for
- Motion of the body impending down the plane.
  - Motion of the body impending up the plane.

(10 Marks)

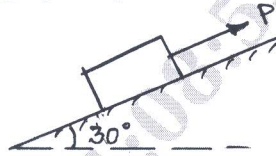

Fig.Q.4(b)

**Module-3**

- 5 a. Define the following:
- Centroid
  - Axis of symmetry.
- b. Find the position of centroid of the given area shown in Fig.Q.5(b) with respect to reference axis. All dimensions are in m.

(02 Marks)

(08 Marks)

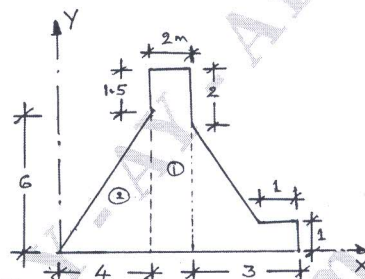

Fig.Q.5(b)

- c. Find the polar radius of gyration of the given area shown in Fig.Q.5(c) with respect to its centroidal axis. All dimensions are in mm.

(10 Marks)

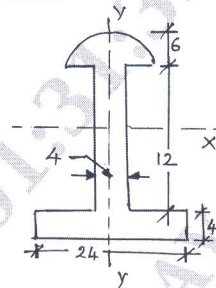

Fig.Q.5(c)

OR

- 6 a. State and prove parallel axis theorem. (04 Marks)
- b. Find the moment of inertia of a rectangular area with respect to its centroidal axis from first principles/method of integration. (06 Marks)
- c. Locate the centroid of the shaded area shown in Fig.Q.6(c) with respect to the X and Y axis. (10 Marks)

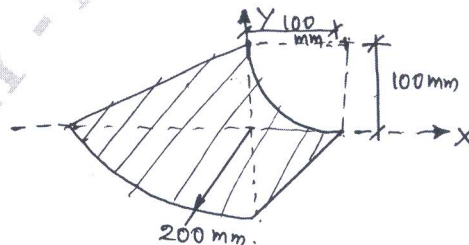

Fig.Q.6(c)

**Module-4**

- 7 a. Differentiate between 'determinate and indeterminate' structure with an example for each. (06 Marks)
- b. Explain the different types of beams and supports. (06 Marks)
- c. Determine reactions at A and E for the beam shown in Fig.Q.7(c). (08 Marks)

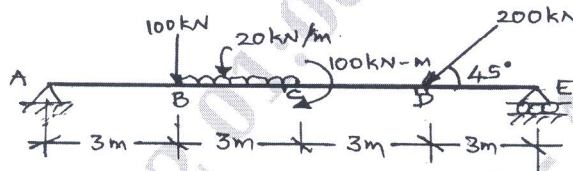

Fig.Q.7(c)

**OR**

- 8 a. List the assumptions made in the analysis of truss. (04 Marks)
- b. Explain different types of loads. (03 Marks)
- c. Determine the magnitude and nature of forces in the members of the truss shown in Fig.Q.8(c) by method of joints. (13 Marks)

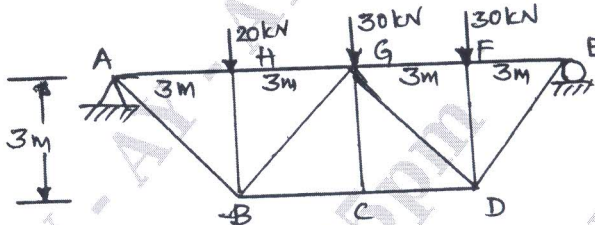

Fig.Q.8(c)

**Module-5**

- 9 a. What is Super elevation? Why it is required? (04 Marks)
- b. Two cars P and Q accelerates from a standing start. The acceleration of P is  $1.3\text{m/s}^2$  and that of Q is  $1.6\text{m/s}^2$ . If Q starts initially 6m behind P, how long it takes to overtake P? (08 Marks)
- c. A stone 'A' is dropped from a tower of 50m height. At the same height, another stone B is thrown up from the front of the tower with velocity of 25m/s. At what distance from top and after how much time the two stones will cross each other. (08 Marks)

**OR**

- 10 a. State D' Alembert's principle. Mention its application for the case of plane motion. (04 Marks)
- b. Two stones A and B are projected from the same point at an inclination of  $45^\circ$  and  $30^\circ$  respectively to the horizontal. Find the ratio of velocities of projection of A and B, if the maximum height reached by them is same. (08 Marks)
- c. A pilot flying his bomber at a height of 2000m with uniform horizontal velocity of 600kmph wants to strike a target. At what distance from the target he should release the bomb. (08 Marks)

\*\*\*\*\*