

USN

--	--	--	--	--	--	--

18MT63



Sixth Semester B.E. Degree Examination, July/August 2022
(Mechatronics Engineering)

COMPUTER AIDED MACHINE DRAWING

Time: 3 Hours

Max. Marks: 100

Instructions to Candidates:

1. Answer any **ONE** question from each part
2. Use **FIRST ANGLE** projection only.
3. Missing data if any may suitably be assumed and mentioned
4. All the dimensions are in mm.
5. Usage of calculators and drawing instruments are allowed

PART - A

1. A hexagonal pyramid side of base 30 mm and altitude 70 mm rests with its base on the HP and with a side of base parallel to the VP. It is cut by a cutting plane inclined at 35° to the HP and perpendicular to the VP and is bisecting the axis. Draw the front view, the sectional view looking from top and true shape of section. (25 Marks)

2. Draw the orthographic projection of Figure 1 with all three views. (25 Marks)

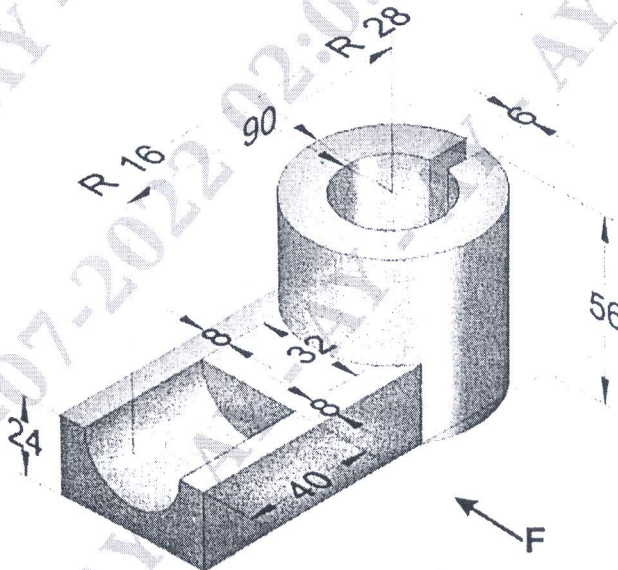

Figure 1.

PART - B

3. Draw the following views of Knuckle joint by taking diameter of the rods $d=20\text{mm}$, all the proportions are expressed in terms of the diameter d of the rods
- Front view with the top half in section
 - Top view
- (25 Marks)
4. Draw the sectional front view and side view of a Protected type flanges coupling to connect two rods of Diameter 20 mm. Indicate all dimensions.
- (25 Marks)

PART - C

5. Figure 2 shows the details of a screw jack. Assemble the parts of the screw jack and show the following views.
- Half sectional front view showing the right half in section
 - Top view
- (50 Marks)
6. Figure 3 shows the details of a Connecting rod for Petrol Engine. Assemble The parts of the Connecting rod and show the following views
- Half sectional front view showing the left half in section
 - Side view
- (50 Marks)

Details of a Screw Jack

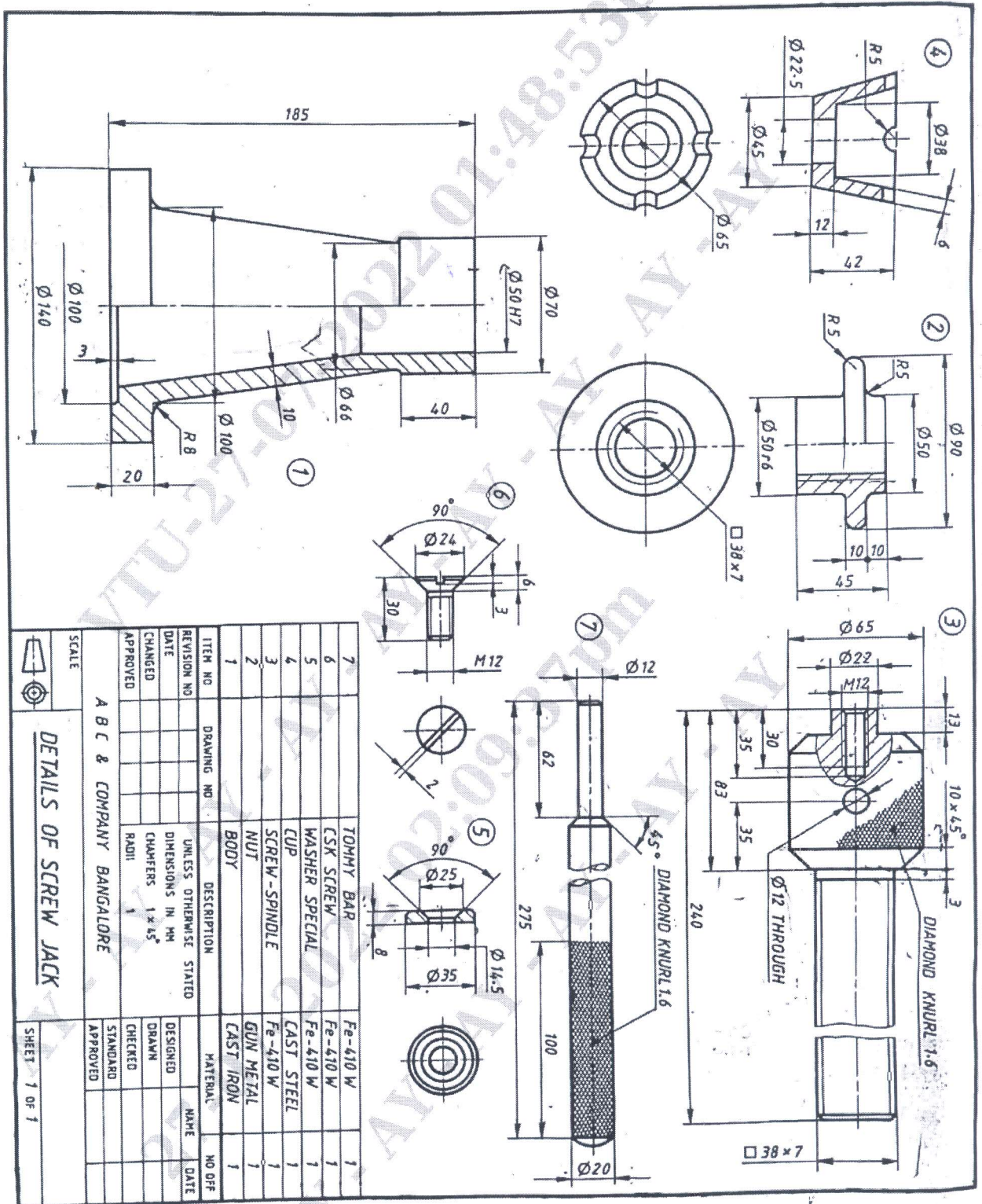

Figure 2: Details of Screw Jack

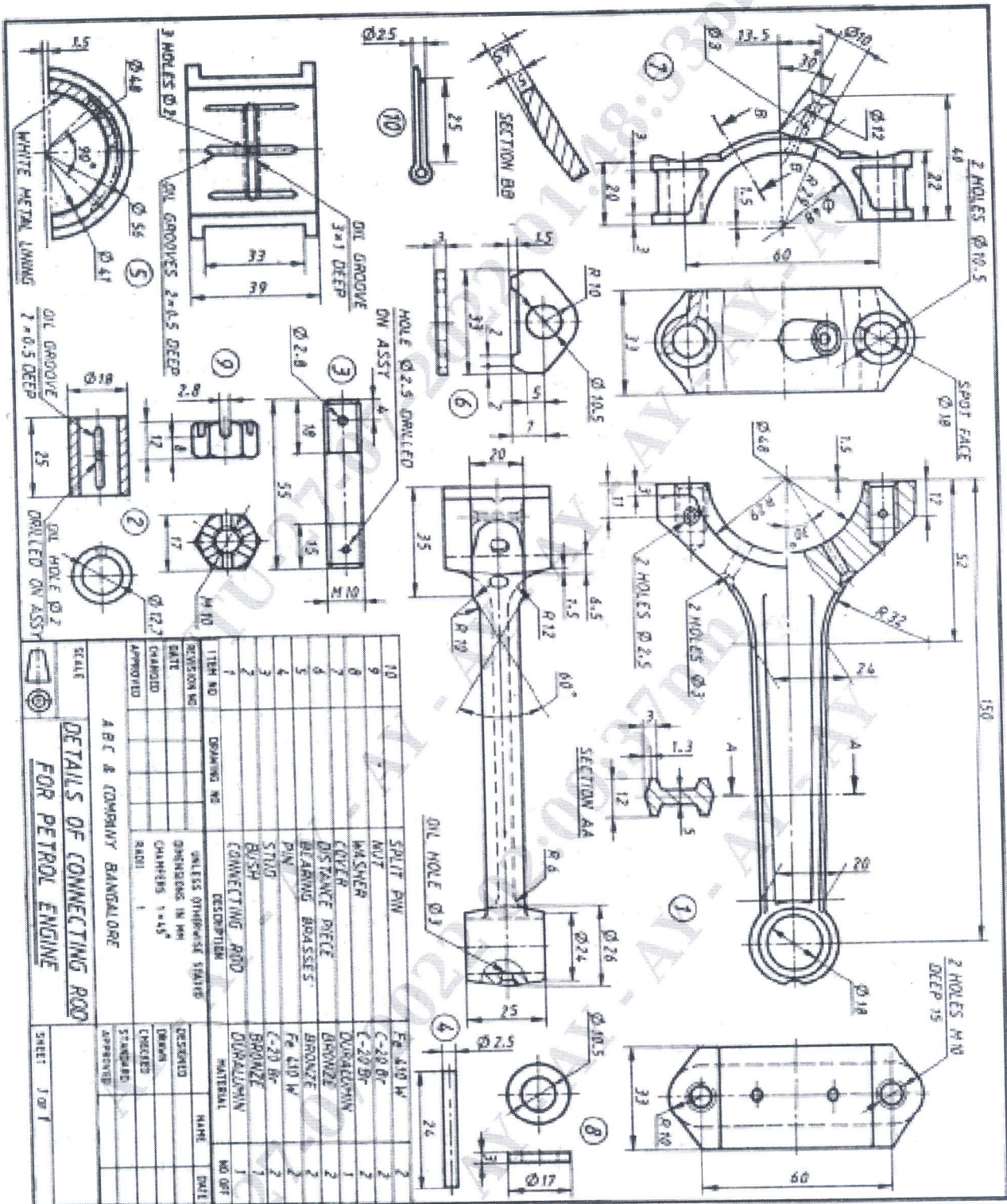

Figure 3: Details of Connecting rod of IC Engine