

USN

--	--	--	--	--	--	--	--

17ME73

Seventh Semester B.E. Degree Examination, July/August 2022
Control Engineering

Time: 3 hrs.

Max. Marks: 100

Note: 1. Answer any FIVE full questions, choosing ONE full question from each module.
2. Write neat sketches, wherever required.

Module-1

- 1 a. Explain loop control system, with an example and block diagram. (07 Marks)
- b. Explain briefly the requirements of an ideal control system. (06 Marks)
- c. With an example and block diagram, explain the closed loop control system. (07 Marks)

OR

- 2 a. Define controllers. Enumerate the classification of the controllers. (04 Marks)
- b. Explain the PI controller. Enumerate its characteristics. (08 Marks)
- c. Explain the PID controller. Enumerate the characteristics of PID controllers. (08 Marks)

Module-2

- 3 a. Obtain the transfer function of the mechanical system shown in Fig. Q3 (a). (10 Marks)

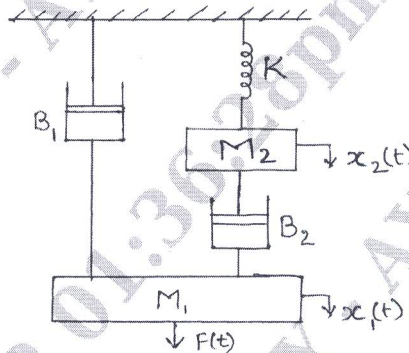

Fig. Q3 (a)

- b. Obtain the transfer function of an armature controlled DC motor. (10 Marks)

OR

- 4 a. Obtain the closed loop transfer function of the system shown in Fig. Q4 (a) by block diagram reduction technique. (10 Marks)

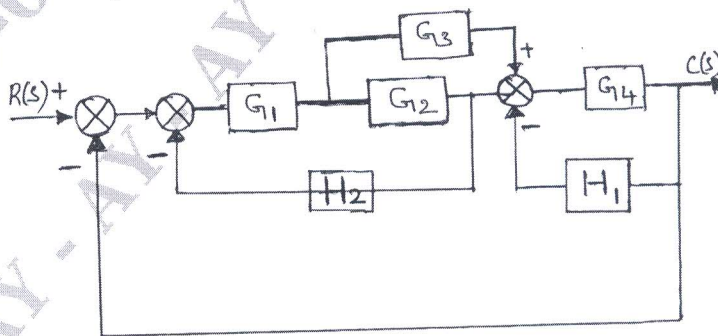

Fig. Q4 (a)

Important Note : 1. On completing your answers, compulsorily draw diagonal cross lines on the remaining blank pages.
2. Any revealing of identification, appeal to evaluator and /or equations written eg, 42+8 = 50, will be treated as malpractice.

- b. Using Mason's gain formula, find $\frac{X_2(s)}{X_1(s)}$ for the system shown in Fig. Q4 (b). (20 Marks)

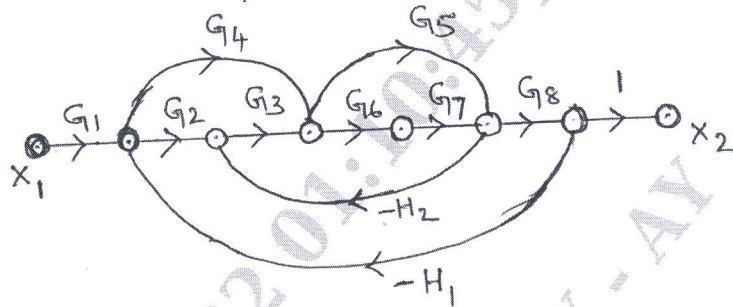

Fig. Q4 (b)

Module-3

- 5 a. Obtain an expression for a second order system subjected to unit step response for an under damped system. (08 Marks)
- b. An unity feed back system with $G(S) = \frac{9}{S^3 + RS^2 + 3KS}$ is conditionally stable. Find K_{mar} and R , if the system oscillates with a frequency of 6 radians/sec. (06 Marks)
- c. A system is represented by $\frac{d^2y}{dt^2} + 4\frac{dy}{dt} + 8y = 8x$, where y is the output and x is the input. Find (i) Delay time (ii) % M_p (iii) Settling time. (06 Marks)

OR

- 6 Plot the root locus for the given transfer function $G(s)H(s) = \frac{K}{s(s+2)(s+4)(s+6)}$. Find the range of K and comment on the stability of the system. (20 Marks)

Module-4

- 7 a. Sketch the polar plot for the system with $G(s)H(s) = \frac{1}{(1+T_1s)(1+T_2s)(1+T_3s)}$. (06 Marks)
- b. Sketch the Nyquist plot for the system with $G(s)H(s) = \frac{40}{(s+4)(s^2+2s+2)}$. Comment on the stability of the system. (14 Marks)

OR

- 8 Sketch the Bode plot for the system with $G(s)H(s) = \frac{2(s+0.25)}{s^2(s+1)(s+0.5)}$. From the plot determine (i) Phase cross over frequency (ii) Gain cross over frequency (iii) Gain margin (iv) Phase margin. Comment on the stability of the system. (20 Marks)

Module-5

- 9 a. What is system compensation? Explain the two types of system compensation. (06 Marks)
- b. Explain Lead compensation. Enumerate the effects and limitations of lead compensator. (07 Marks)
- c. Explain Lag compensation. Enumerate the effects and limitations of Lag compensator. (07 Marks)

OR

10 a. Explain the following terms:

- (i) State variables.
- (ii) State vector.
- (iii) State
- (iv) State space.
- (v) State trajectory.

(05 Marks)

b. Determine the state controllability and observability of the system by Kalman's test.

$$\dot{X} = \begin{bmatrix} 0 & 1 & 0 \\ 0 & 0 & 1 \\ 0 & -2 & -3 \end{bmatrix} X + \begin{bmatrix} 0 \\ 0 \\ 1 \end{bmatrix} u;$$

$$y = [1 \ 0 \ 0 \ 0]X$$

(15 Marks)
