

USN

--	--	--	--	--	--	--	--	--	--

17AU53

Fifth Semester B.E. Degree Examination, July/August 2022
Design of Machine Elements – I

Time: 3 hrs.

Max. Marks: 100

Note: Answer any FIVE full questions, choosing ONE full question from each module.

Module-1

1. a. Explain standards and codes used in design. (05 Marks)
- b. List and explain the factors to be considered for selection of material for machine component. (05 Marks)
- c. Stresses in a 2D stressed body as shown in Fig. Q1 (c). Determine
 - (i) Normal and tangential stress on a plane inclined at 45° .
 - (ii) Principal stresses and their directions.
 - (iii) Maximum shear stress.

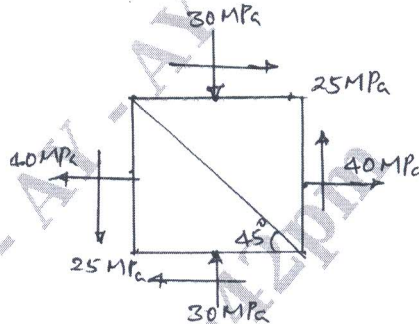

Fig. Q1 (c)

(10 Marks)

OR

2. a. State and explain the following theories of failure:
 - (i) Maximum normal stress theory.
 - (ii) Maximum shear stress theory.
 - (iii) Distortion energy theory. (10 Marks)
- b. A bar of diameter 50 mm subjected to an axial load of 10 kN and twisting moment of 3 kN-m. The bar is made up of steel C30. Find the factor of safety according to,
 - (i) Maximum normal stress theory.
 - (ii) Maximum shear stress theory. (10 Marks)

Module-2

3. a. What is stress concentration? How to reduce it? (05 Marks)
- b. Determine the diameter of member as shown in Fig. Q3 (b) by taking stress concentration into account, if the member is subjected to
 - (i) Bending moment of 200 N-m
 - (ii) Twisting moment of 300 N-m.
 If $\sigma_t = 120$ MPa, $\tau = 60$ MPa (10 Marks)

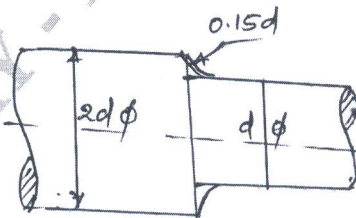

Fig. Q3 (b)

- c. A unknown weight falls through 20 mm on a collar rigidly attached to the lower end of a vertical bar 2 m long and 500 mm^2 section. If the maximum extension is 2 mm. What is the corresponding stress and values of unknown weight? Take $G = 200$ GPa. (05 Marks)

OR

- 4 a. Derive Soderbergs relation for Fatigue failure. (05 Marks)
- b. A Cantilever beam shown in Fig. Q4 (b) is subjected to load varying from $-F$ to $+3F$. Determine the maximum load that the member can withstand for infinite life. The material of beam is cold drawn SAE1025. Assume Notch sensitivity = 0.9, Size factor = 0.85, Surface factor = 0.88, $\sigma_u = 550$ MPa, $\sigma_y = 470$ MPa, $\sigma_m = 275$ MPa, FOS = 2. (15 Marks)

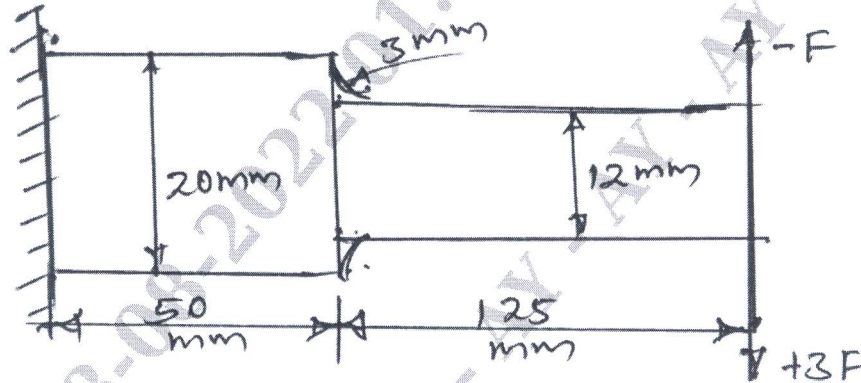

Fig. Q4 (b)

Module-3

- 5 a. Design a rigid CI flanged coupling used transmit 50 kW at 300 rpm. The overall torque is 20% greater than mean torque. The allowable shear stress for shaft is 40 MPa and shear stress for CI flange is 15 MPa. Assume key shaft and bolt are made up of same material. (10 Marks)
- b. Design the knuckle joint to transmit a load of 40 kN. The material selected for joint has the following design stress:
 $\sigma_t = 100$ MPa, $\sigma_c = 120$ MPa, $\tau = 55$ MPa. (10 Marks)

OR

- 6 A power transmission shaft having length between bearings is 600 mm carries a pulley of 400 mm diameter having weight 400 N mounted at middle of the shaft. The shaft receives 40 kW at 600 rpm by a Flat belt drive. Power from shaft is transmitted through another pulley of diameter 600 mm. Weighing 600 N over hanging at the right hand bearing by 200 mm. The belt drivers on pulley are right angles each other. Take ratio of belt tensions as 3. Determine the diameter of shaft. (20 Marks)

Module-4

- 7 a. Explain the failures in Riveted Joints. (06 Marks)
- b. Design Tripple Riveted zig-zag lap joint for a pressure of 1.5 MPa and diameter of vessel is 1.5 m. The allowable stresses in tension, crushing and shear are 100 MPa, 125 MPa and 75 MPa respectively. (14 Marks)

OR

- 8 a. A plate of 80 mm wide and 15 mm thick is to be welded with another plate by single transverse and double parallel weld. Determine the length of parallel weld if joint is subjected to both static and fatigue loading. Take $\sigma_t = 90$ MPa and $\tau = 55$ MPa. (10 Marks)

- b. Determine the size of weld for welded joint subjected load as shown in Fig. Q8 (b). The permissible shear stress for the material is 75 MPa. (10 Marks)

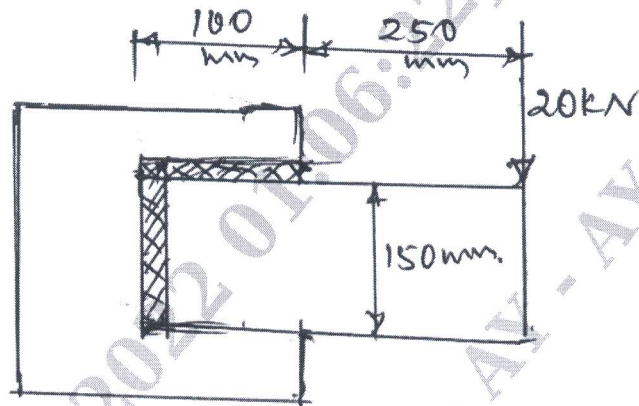

Fig. Q8 (b)

Module-5

- 9 a. A base plate of drilling machine is mounted by three steel bolts equally spaced on a bolt circle of diameter 0.3 m. The diameter of base is 0.4 m. The spindle is positioned at a radial distance of 0.335 m from the column and subjected to a force of 4.5 kN. Determine the size bolt, if the allowable stress in bolt is 100 MPa. (12 Marks)
- b. Explain the stresses induced in a screw, fastening for static and dynamic loading. (08 Marks)

OR

- 10 Design a screw jack with a lift of 300 mm to lift a load of 50 kN. Select steel C40 for screw ($\sigma_y = 328.6$ MPa) Phosphor bronze ($\sigma_{ut} = 345$ MPa, $\sigma_y = 138$ MPa) for nut. (20 Marks)
