

USN

--	--	--	--	--	--	--	--	--	--

18AU43

Fourth Semester B.E. Degree Examination, July/August 2022
Kinematics of Machines

Time: 3 hrs.

Max. Marks: 100

Note: Answer any FIVE full questions, choosing ONE full question from each module.

Module-1

- 1 a. Define the following terms with example:
 (i) Kinematic pair (ii) Kinematic chain (iii) Mechanism
 (iv) Degree of freedom (v) Structure (10 Marks)
- b. What is an Inversion? Give the inversions of double slider crank chain. Explain any one inversion with a neat sketch. (10 Marks)

OR

- 2 a. Sketch and explain the following:
 (i) Peaucellier's mechanism
 (ii) Straight-line motion mechanism
 (iii) Robert's mechanism (10 Marks)
- b. With an aid of neat sketch, explain the working of crank and slotted lever mechanisms. (10 Marks)

Module-2

- 3 A four mechanism has a fixed link $AD = 1$ m driving crank $AB = 0.3$ m, follower link $CD = 0.6$ m and the connecting link is 1.2 m. The crank rotates at a speed of 300 rpm clockwise with an angular acceleration of 200 r/sec^2 in anticlockwise direction. When the angle made by the crank with a fixed link is 135° in anti-clockwise direction, determine:
 (i) Angular velocity of the link BC and CD.
 (ii) Angular acceleration of the link BC and CD
 (iii) Acceleration of B and C (20 Marks)

OR

- 4 a. What is Coriolis component of acceleration? Derive the expression for the same. (08 Marks)
- b. In the mechanism shown in Fig.Q4(b), the slider C is moving to the right with a velocity of 1 m/s and an acceleration of 2.5 m/s^2 . The dimensions of various links are $AB = 3\text{m}$ inclined at 45° with the vertical and $BC = 1.5\text{m}$ inclined at 45° with the horizontal. Determine:
 (i) The magnitude of vertical and horizontal component of acceleration of the point B.
 (ii) The angular acceleration of the links AB and BC.

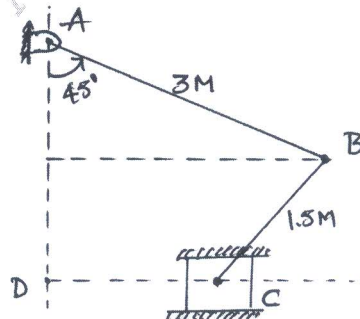

Fig.Q4(b)

1 of 3

(12 Marks)

Module-3

- 5 a. State and prove Kennedy's theorem. (06 Marks)
 b. Locate all the instantaneous centres of the slider crank mechanisms. The length of crank is 0.3 m and the length of connecting rod is 1.5 m. If the crank rotates at 450 rpm clockwise and the crank is inclined at 45° with IDC. Find:
 (i) Velocity of slider
 (ii) Angle velocity of connecting rod (14 Marks)

OR

- 6 The length of the crank and connecting rod of a reciprocating engine are 200 mm and 800 mm respectively. The crank is rotating at a uniform speed of 480 rpm. Using Klein's construction, find:
 (i) Acceleration of piston
 (ii) Acceleration of the Middle point of connecting rod
 (iii) Angular acceleration of the connecting rod when the crank has turned through 45° from the inner dead center. (20 Marks)

Module-4

- 7 a. What is Interference? Explain the method of avoiding it. (08 Marks)
 b. Two gear wheels mesh externally are to give a velocity ratio of 3. Involute teeth arc of 6 mm module and 20° of pressure angle. The standard addendum is one module and the pinion rotates at 400 rpm. Find number of teeth on each wheel, so that the interference is just avoided, length of path of contact, maximum velocity of sliding between the teeth, arc of contact and contact ratio. (12 Marks)

OR

- 8 a. Name different types of gear trains. Explain any one gear train with a neat sketch. (08 Marks)
 b. The Fig.Q8(b) shows an epicyclic gear train where the arm 'A' is the driver and annular gear 'D' is the follower. The wheel 'D' has 112 teeth and 'B' has 48 teeth, B runs freely on 'P' and 'D' is separately driven. The arm 'A' runs at 100 rpm and the wheel 'D' at 50 rpm in same direction, find the torque on 'B' if A receives 7.5 KW.

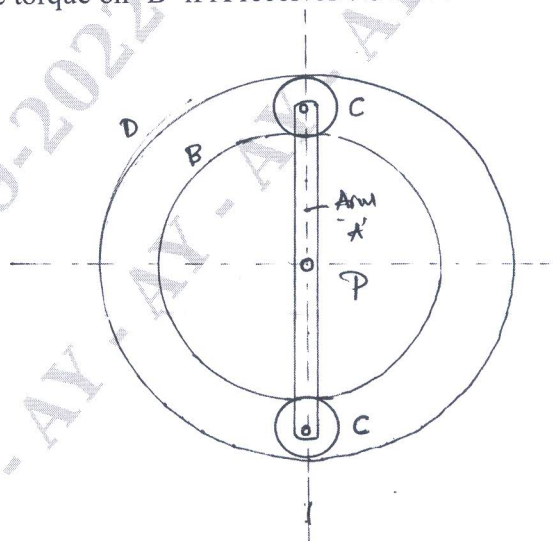

Fig.Q8(b)

(12 Marks)

Module-5

- 9 A cam rotating clockwise at uniform speed of 300 rpm operates a reciprocating follower through a roller 1.5 cm diameter. The follower motion is defined as below:
- Outward during 150° with UARM
 - Dwell for next 30°
 - Return during next 120° with SHM
 - Dwell for the remaining period
- Stroke of the follower is 3 cm. Minimum radius of the cam is 3 cm. Draw the cam profile. (20 Marks)

OR

- 10 a. Define the following as applied to a cam with a neat sketch:
- Base circle
 - Pitch circle
 - Pressure angle
 - Stroke of the follower
- (06 Marks)
- b. Draw the profile of a cam operating knife edge follower having a lift of 30 mm. The cam raises the follower with SHM for 150° of the rotation followed by a period of dwell for 60° . The follower descends for next 100° rotation of the cam with uniform velocity, again followed by a dwell period. The cam rotates in an anticlockwise sense at a uniform velocity of 120 rpm and has a least radius of 25 mm. What will be the maximum velocity and acceleration of the follower during the lift? (14 Marks)
