

Sixth Semester B.Arch. Degree Examination, Aug./Sept. 2020
Structures - VI

Time: 3 hrs.

Max. Marks:100

Note: 1. Answer any FIVE full questions.
2 Use of IS 800-2007, SP6 and steel table is allowed.

- 1 a. What are the advantages and disadvantages of steel structures? (08 Marks)
- b. Design a single bolted double cover butt joint to connect boiler plates of thickness 12mm for maximum efficiency. Use M16 bolts of grade 4.6 Boiler plates are of Fe 410 grade. Find the efficiency of the joint. (12 Marks)

- 2 a. Define the following terms with neat sketches. (08 Marks)
 - (i) Pitch of the bolts
 - (ii) Edge distance
 - (iii) Staggered distance
 - (iv) End distance
 - (v) Gauge distance
- b. A bracket plate bolted to a vertical column is loaded as shown in Fig Q2(b). If M20 bolts of grade 4.6 are used, determine the maximum value of factored load 'P' which can be carried safely.

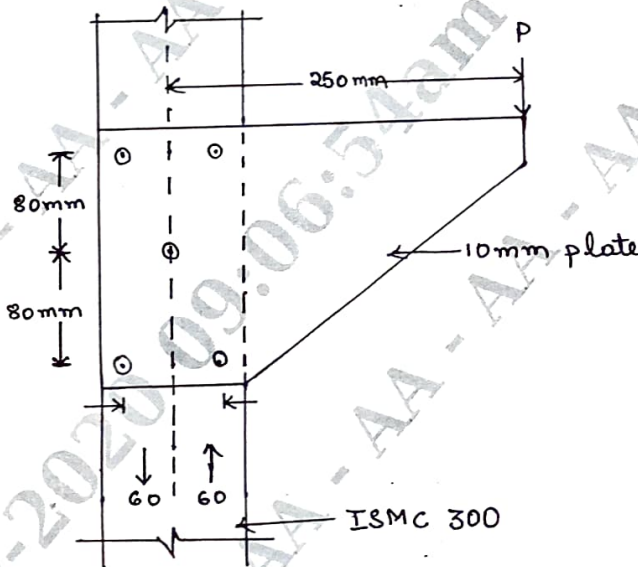

Fig Q2(b)

(12 Marks)

- 3 a. List and briefly explain advantages and disadvantages of welded connection over bolted connection. (05 Marks)
- b. Design a suitable longitudinal fillet weld to connect the plates as shown in Fig Q3(b) to transmit a pull equal to the full strength of small plate. Plates are 12mm thick with grade Fe 410 and welded connection.

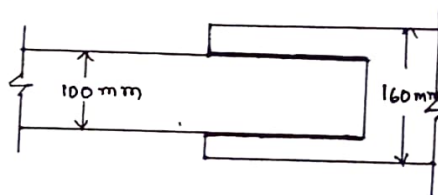

Fig Q3(b)

(15 Marks)

- 4 a. Explain different types of welds with neat sketches. (08 Marks)
- b. A plate bracket, carrying a load of 100kN at an eccentricity of 120mm, is connected to the face of a steel stanchion by fillet welds on both the sides of the plate as shown in Fig Q4(b).
- Determine the size of the fillet weld
 - If 8mm fillet weld is used, determine the depth of the bracket
 - If 8mm fillet weld is used with a bracket of 250mm depth, calculate the resulting stress in the weld.

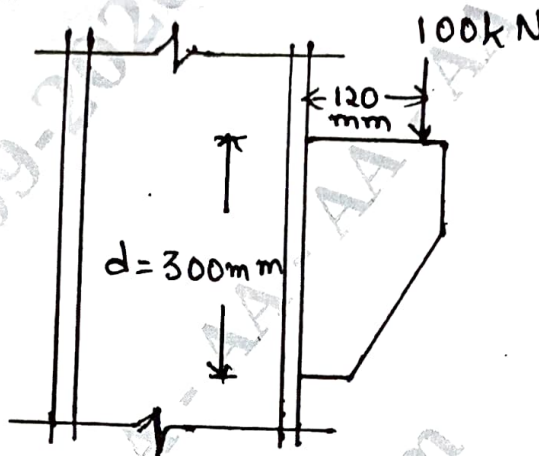

Fig Q4(b)

(12 Marks)

- 5 Design a load column with two channel back to back of length 10m to carry an axial factored load of 1400kN. The column may be assumed to have restrained position but not in direction at both ends (hinged ends). (20 Marks)
- 6 Design a slab base for a column ISHB 300@577N/m carrying an axial factored load of 1000kN-M20 concrete is used for the foundation. Provide welded connection between column and base plate. (20 Marks)
- 7 Design a simply supported beam of effective span 1.5m carrying a factored concentrated load of 360kN at mid span. (20 Marks)
- 8 Explain the following :
- Design steps in lacing system.
 - Defect in welded connections
 - Fire protection of steel structures
 - Advantages and disadvantages of bolted connections.

(20 Marks)