

Sixth Semester B.E. Degree Examination, Feb./Mar. 2022
Finite Element Methods

Time: 3 hrs.

Max. Marks:100

Note: Answer any FIVE full questions, selecting atleast TWO questions from each part.

PART – A

- 1 a. Derive equilibrium equations in elasticity subjected to body force in 3 dimensions with usual notations. (08 Marks)
- b. Briefly explain the steps involved in FEM. (07 Marks)
- c. Define plane stress and plane strains with example and write stress strain relations.(05 Marks)

- 2 a. Using Rayleigh Ritz method, find the maximum deflection of a simply supported beam with point load at center. (10 Marks)
- b. State principle of minimum potential energy and principle of virtual work. (04 Marks)
- c. Derive the stiffness matrix for bar element using direct approach. (06 Marks)

- 3 a. Explain simplex, complex and multiple elements. (05 Marks)
- b. Write a note on convergence criteria. (05 Marks)
- c. Derive the shape function for bar element in global co-ordinate system. List the properties of shape function. (10 Marks)

- 4 a. Solve the following system of simultaneous equations by Gauss Elimination method.
 $x_1 - 2x_2 + 6x_3 = 0$
 $2x_1 + 2x_2 + 3x_3 = 3$
 $-x_1 + 3x_2 = 2$ (10 Marks)
- b. Consider a bar shown in Fig Q4(b), An axial load $P = 60\text{kN}$ is applied at its mid point. Using penalty method of Boundary condition, determine the nodal displacement and Reactions.

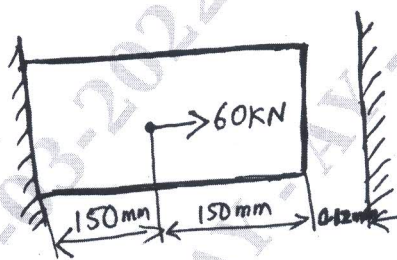

$A = 250\text{mm}^2$
 $E = 200\text{GPa}$

Fig Q4(b)

(10 Marks)

PART – B

- 5 a. Derive the shape function for 2-D linear quadrilateral element. (10 Marks)
- b. Evaluate the integral $I = \int_{-1}^{+1} [3\xi^3 + 2\xi^2 + \xi + 2]d\xi$ by using 2 point and 3 point Gauss quadrature. (10 Marks)

Important Note : 1. On completing your answers, compulsorily draw diagonal cross lines on the remaining blank pages.
2. Any revealing of identification, appeal to evaluator and/or equations written eg. 42+8 = 50, will be treated as malpractice.

- 6 a. Derive the stiffness matrix of Truss element. (10 Marks)
 b. For the two bar truss shown in Fig Q6(b). Determine the nodal displacement and stresses in each element. Take $E = 2 \times 10^5 \text{ N/mm}^2$; $A = 200\text{mm}^2$

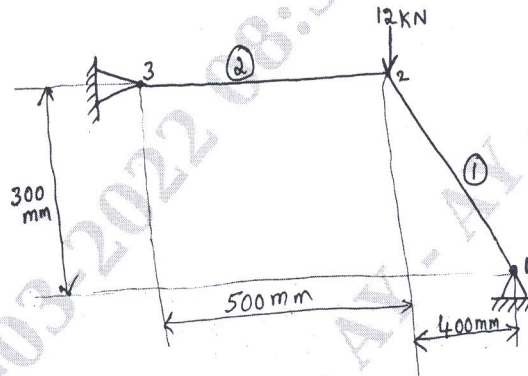

Fig Q6(b)

(10 Marks)

- 7 a. Derive Hermite shape function of Beam element. (10 Marks)
 b. For the beam shown in Fig Q7(b), determine the deflection at mid span and determine the end reaction. Take $E = 200\text{GPa}$ and $I = 4 \times 10^6 \text{ mm}^4$

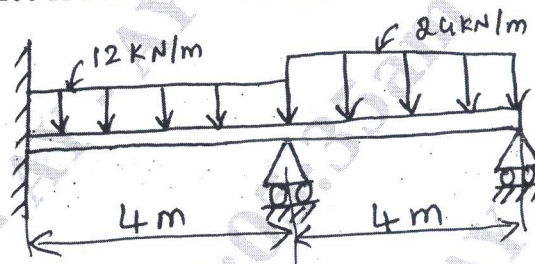

Fig Q7(b)

(10 Marks)

- 8 a. Determine the temperature distribution through the composite walls subjected to convection heat loss on the right side surface with convective heat transfer coefficient shown in Fig Q8(a). The ambient temperature is -5°C

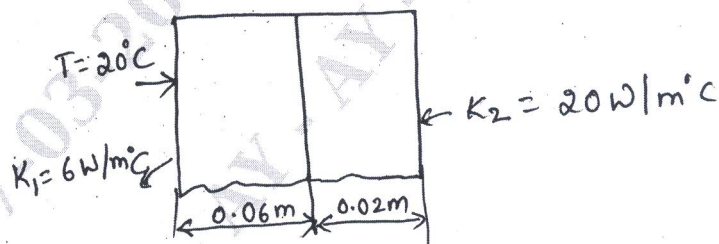

Fig Q8(a)

(10 Marks)

- b. Discuss the Galerkin approach for 1-D heat conduction problem. (10 Marks)
