

USN										
-----	--	--	--	--	--	--	--	--	--	--

Third Semester B.E. Degree Examination, Feb./Mar. 2022

COMPUTER AIDED MACHINE DRAWING

Time: 3 Hours

Max. Marks: 100

- Note:
1. Answer any ONE question from each of the parts A, B and C.
 2. Use **First angle** projections only.
 3. If any data is missing it may be suitably assumed and mentioned.
 4. All the calculations should be on the answer sheet supplied.
 5. All the dimensions are in mm.
 6. Drawing instruments may or may not be used for sketching.
 7. Part C assembly view should be in 3-D and other views in 2-D.

Part – A

1. Draw the (i) the sectional view from the front and (ii) the view from the left of a shaft support shown in the figure 1

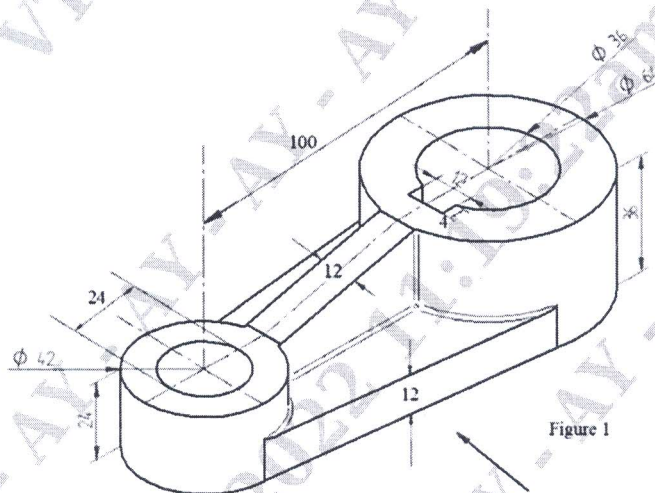

Figure 1

25 Marks

2. Draw two views of square headed bolt with nut for a 25mm diameter bolt. Take length of bolt equal to 100mm.

25 Marks

Part – B

3. Draw the following view of a SOCKET and SPIGOT COTTER JOINT used to joining two rods of diameter 30mm (a) Sectional front view (b) A view looking from socket end. **25 Marks**
4. Draw sectional front view and side view of a Universal Coupling to connect two rods of diameter 25mm, indicate all dimensions. **25 Marks**

Part – C

5. Figure 2 shows the details of a Machine vice. Assemble the parts of the Machine vice and show the following views.
- a. Half sectional front view.
 - b. Top view.
- 50 Marks**
6. Figure 3 shows the part drawing of a tail stock. Assemble the tail stock and show the following views.
- a. Sectional front view showing the top spindle portion in section.
 - b. Left profile view.
- 50 Marks**

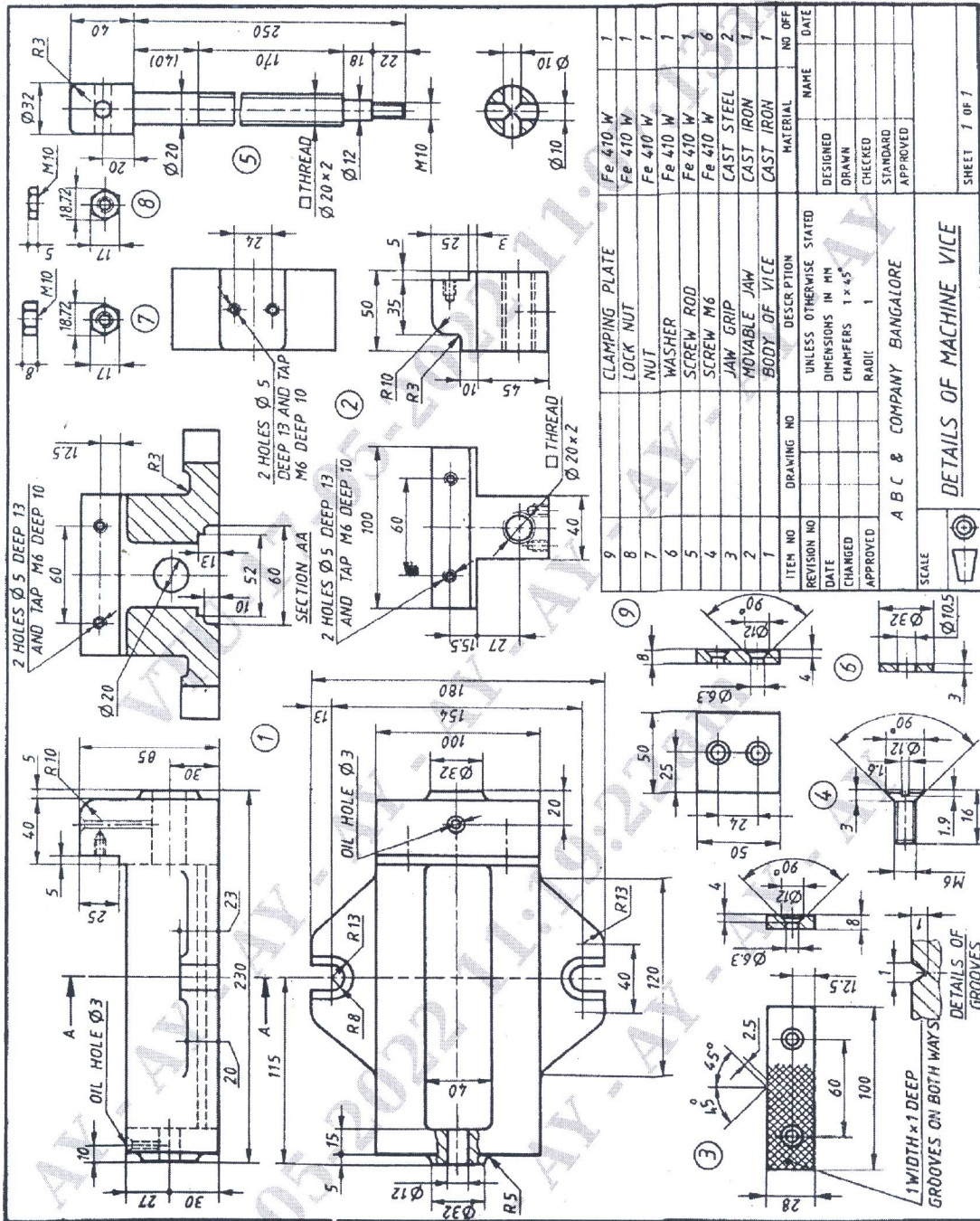

Figure 2 : Details of Machine Vice

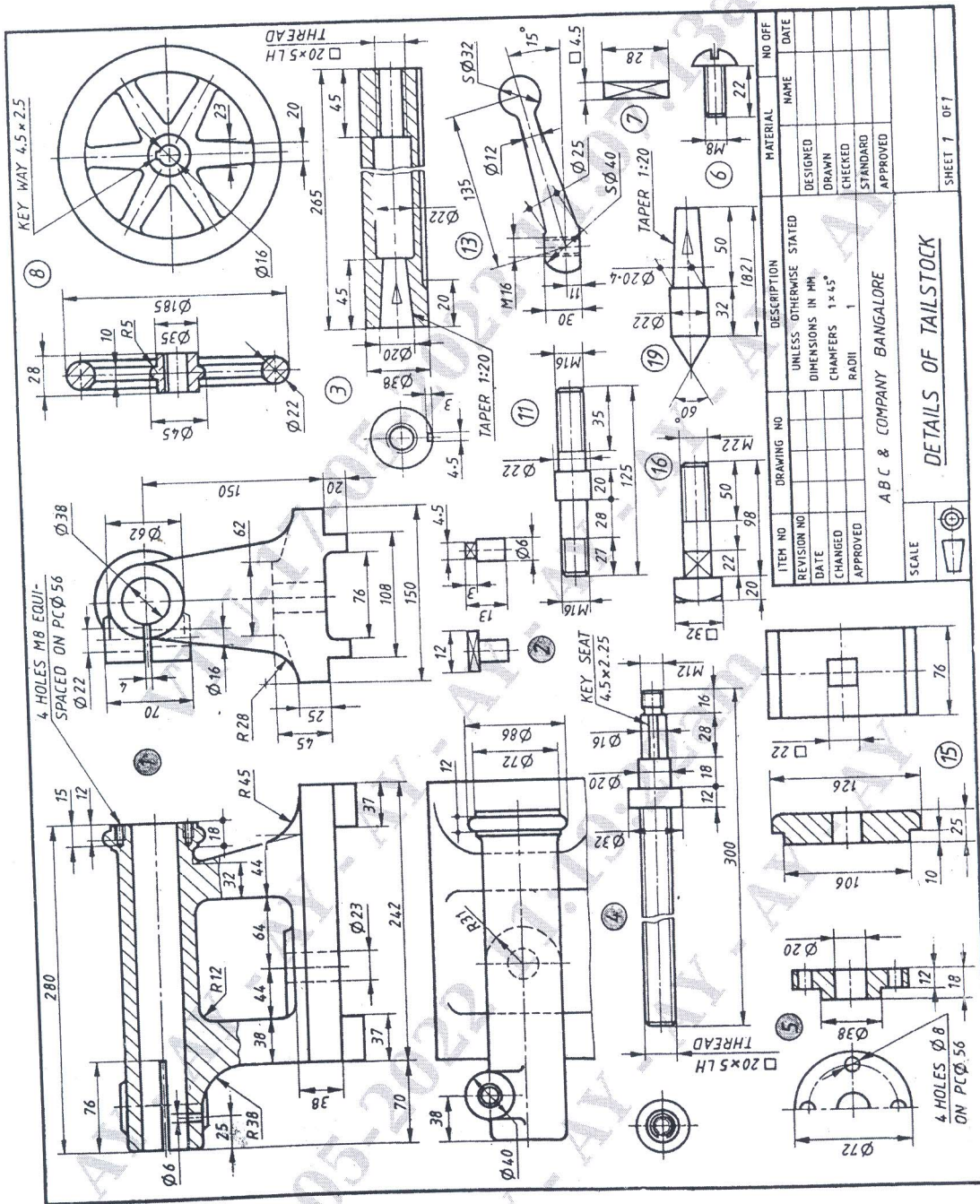

Figure 3 : Details of a tail stock