

USN									
-----	--	--	--	--	--	--	--	--	--

Fifth Semester B.E. Degree Examination, July/August 2021 Dynamics of Machinery

Time: 3 hrs.

Max. Marks: 80

Note: Answer any FIVE full questions.

- 1 a. State the conditions for the equilibrium of the following systems :
 - i) Two force member
 - ii) Three force member
 - iii) Member with two forces and a torque

(06 Marks)
- b. Determine the driving torque T_2 on the crank of a slider crank mechanism shown in Fig Q1(b) for static equilibrium.

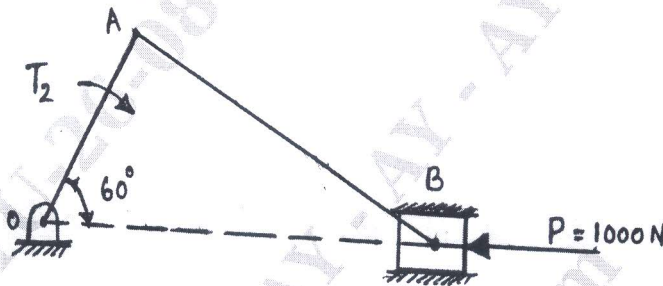

OA = 100mm
AB = 300mm

Fig Q1(b)

(10 Marks)

- 2 a. State and explain D'Alembert's principle. (08 Marks)
- b. When the crank is 45° from the inner dead centre on the down stroke, the effective steam pressure on the Piston of a vertical steam engine is 2.5 bars. The diameter of the cylinder = 0.75m, Stroke of the piston = 0.50m and length of the connecting rod = 1m. Determine the torque on the crank shaft, if the engine runs at 350rpm and the mass of the reciprocating parts is 200kg. (08 Marks)
- 3 a. Explain briefly Static and Dynamic balancing. (04 Marks)
- b. A shaft carries four masses A, B, C and D of magnitude 200kg, 300kg, 400kg and 200kg respectively and revolving at radii 80mm, 70mm, 60mm and 80mm respectively. The distances from the plane A are 300mm, 400mm and 700mm. The angles between the cranks measured anticlockwise are A to B 45° , B to C 70° and C to D 120° . The balancing masses are to be placed in planes X and Y. the distances between the planes A and X is 100mm, between X and Y is 400mm and between Y and D is 200mm. If the balancing masses revolve at a radius of 100mm, find their magnitudes and angular positions. (12 Marks)
- 4 a. With usual notations, explain the primary and secondary unbalanced forces of reciprocating masses. (04 Marks)
- b. A four crank engine has two outer cranks set at 120° to each other and their reciprocating masses are each 400kg. The distance between planes of rotation of adjacent cranks are 450mm, 750mm and 600mm. If the engine is to be in complete primary balance, find the reciprocating mass and the relative angular position for each of the inner cranks. If the length of each crank is 300mm, the length of each connecting rod is 1.2m and the speed of rotation is 240rpm, find the maximum secondary unbalanced force. (12 Marks)

Important Note : 1. On completing your answers, compulsorily draw diagonal cross lines on the remaining blank pages.
2. Any revealing of identification, appeal to evaluator and /or equations written eg, 42+8 = 50, will be treated as malpractice.

- 5 a. Derive an expression for the Gyroscopic couple $C = I. \omega. \omega_p$.
- b. In a spring loaded Hartnell governor the extreme radii of rotation of the balls are 80mm and 120mm. The balls arm and sleeve arm of the bell crank lever are equal in length. The mass of each ball is 2kg. If the speeds at the two extreme positions are 400rpm and 420 rpm. Find:
- Spring stiffness
 - Initial compression of the central spring
 - Sleeve lift.

(10 Marks)

- 6 a. Define :

- Sensitiveness
- Stable Governor
- Governor power

(06 Marks)

- b. The rotor of the turbine of a ship has a mass of 5000kg and rotates at a speed of 2100rpm clockwise when viewed from stern. The rotor has a radius of gyration 0.5m. Determine the gyroscopic couple and its effect when,
- The ship steers to the left in a curve of 60m radius at a speed of 16 knots (1 knot = 1860m/hr)
 - The ship pitches 6° above and 6° below the horizontal position and the bow is descending with its maximum velocity. The pitching motion is simple harmonic with a periodic time of 20 seconds
 - The ship rolls and at that instant the angular velocity is 0.03 rad/sec clockwise when viewed from the stern.

(10 Marks)

- 7 a. Define the following terms :

- Natural frequency
- Degrees of freedom
- Resonance
- Free and forced vibrations
- Damped and undamped vibrations

(10 Marks)

- b. Add the following motions analytically

$$x_1 = 3 \sin(\omega t + 30^\circ), x_2 = 4 \cos(\omega t + 10^\circ)$$

(06 Marks)

- 8 a. Derive the differential equation of a spring mass system using Newton's and Energy method.
- b. Two masses m_1 and m_2 are connected to the rod as shown in Fig Q8(b). Determine the natural frequency of the system.

(08 Marks)

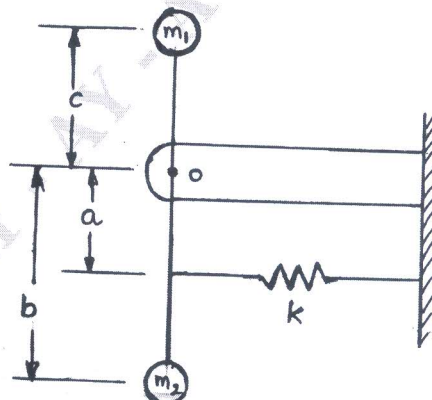

Fig Q8(b)

(08 Marks)

- 9 a. Define logarithmic decrement. Show that logarithmic decrement δ is given by $\frac{2\pi\xi}{\sqrt{1-\xi^2}}$ for underdamped system. (06 Marks)
- b. A spring mass damper system has $m = 3\text{kg}$, $k = 100\text{N/m}$, $c = 3 \text{ N-sec/m}$. Determine :
- Damping factor
 - Natural frequency of damped vibration
 - Logarithmic decrement
 - The ratio of two successive amplitudes
 - Number of cycles after which the original amplitude is below 20% (10 Marks)
- 10 a. Show that providing damping in vibration isolation is not useful when the frequency ratio is more than $\sqrt{2}$ or 1.44. (06 Marks)
- b. A machine of total mass 17kg is mounted on springs having stiffness $K = 11 \times 10^5\text{N/m}$. A Piston within the machine has a mass of 2kg has a reciprocating motion with stroke 7.5cm and speed 6,000rpm. Assuming the motion to be S.H.M. Determine :
- Maximum amplitude of vibration
 - Transmissibility
 - Force transmitted to the ground or foundation.
- Take $\xi = 0.2$. (10 Marks)
