

CBCS SCHEME

USN

--	--	--	--	--	--	--	--	--	--

15ME61

Sixth Semester B.E. Degree Examination, Aug./Sept.2020 Finite Element Method

Time: 3 hrs.

Max. Marks: 80

Note: Answer any FIVE full questions, choosing ONE full question from each module.

Module-1

- 1 a. Explain briefly about Node location system and numbering scheme. (06 Marks)
- b. For the spring system shown in Fig.Q1(b), using principle of minimum potential energy, determine the nodal displacements. Take $F_1 = 75\text{N}$, $F_2 = 100\text{N}$.

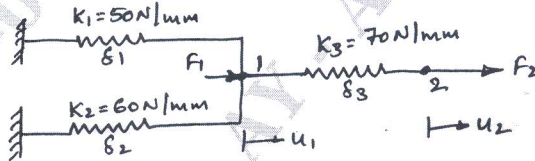

Fig.Q1(b)

(10 Marks)

OR

- 2 a. State and explain convergence requirements. (04 Marks)
- b. Write a short note on :
 - (i) Geometrical isotropy for 2D Pascal triangle. (06 Marks)
 - (ii) Coordinate system. (06 Marks)
- c. Explain simplex, complex and multiplex elements. (06 Marks)

Module-2

- 3 a. Derive the shape function for triangular (CST Element) in natural coordinate system. (08 Marks)
- b. Derive the shape functions for a 4-node Quadrilateral element in natural co-ordinates. (08 Marks)

OR

- 4 a. Obtain an expression for stiffness matrix of a truss element. (06 Marks)
- b. Find the nodal displacement, stress and reaction of truss element shown in Fig.Q4(b). Take $E = 200\text{ GPa}$.

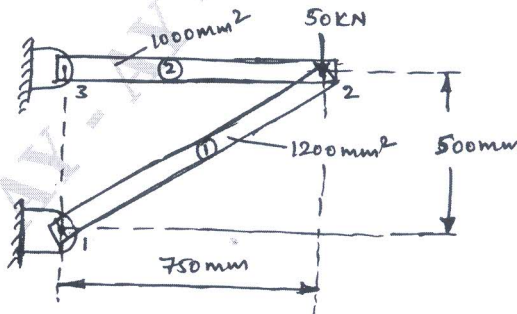

Fig.Q4(b)

(10 Marks)

Important Note : 1. On completing your answers, compulsorily draw diagonal cross lines on the remaining blank pages.
2. Any revealing of identification, appeal to evaluator and /or equations written eg, 42+8 = 50, will be treated as malpractice.

Module-3

- 5 a. Derive the Hermite function for a beam element. (08 Marks)
 b. For the beam and loading shown in Fig.Q5(a), determine the slopes at 2 and 3 and the vertical deflection at the midpoints of the distributed load. Take $E = 200 \text{ GPa}$, $I = 4 \times 10^6 \text{ mm}^4$.

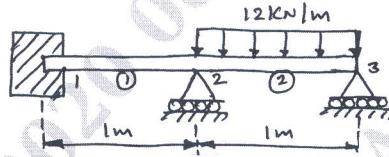

Fig.Q5(a)

(08 Marks)

OR

- 6 a. Derive the stiffness matrix for a circular shaft subjected to pure torsion. (08 Marks)
 b. A solid stepped bar of circular c/s shown in Fig.Q6(b) is subjected to a torque of 1 kN-m at its free end and torque of 3 kN-m at its change in c/s section. Determine the angle of twist and shear stress in the bar. Take $E = 2 \times 10^5 \text{ N/mm}^2$, $G = 7 \times 10^4 \text{ N/mm}^2$.

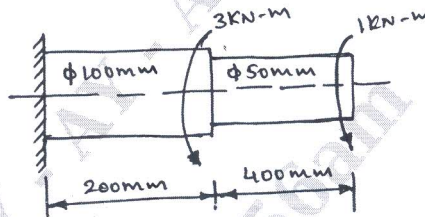

Fig.Q6(b)

(08 Marks)

Module-4

- 7 a. Derive element conductivity matrix for 1-dimensional heat flow element. (06 Marks)
 b. Determine the temperature distribution through the composite wall subjected to convection heat loss on the right side surface with convective heat transfer co-efficient as shown in Fig.Q7(b). The ambient temperature is -5°C .

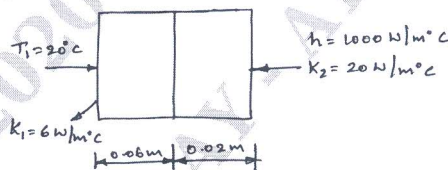

Fig.Q7(b)

(10 Marks)

OR

- 8 a. Derive the stiffness matrix for 1D fluid element. (08 Marks)
 b. For the smooth pipe shown in Fig.Q8(b), with uniform c/s of 1 m^2 . Determine the flow velocities at the centre and right end, knowing the velocity at the left is $V_x = 2 \text{ m/s}$.

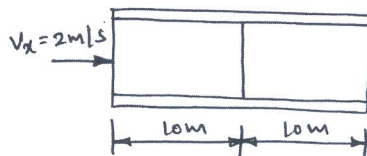

Fig.Q8(b)

(08 Marks)

Module-5

- 9 a. Derive the shape function for an axisymmetric triangular element. (08 Marks)
 b. For the element of an axisymmetric body rotating with a constant angular velocity $\omega = 1000$ rev/min as shown in Fig.Q9(b), determine the body force vector. Include the weight of the material, where the specific density is 7850 kg/m^3 .

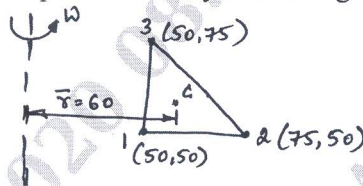

Fig.Q9(b)

(08 Marks)

OR

- 10 a. Derive the consistent mass matrix for bar element. (06 Marks)
 b. Determine the natural frequency of longitudinal vibration of the bar shown in Fig.Q10(b). Take, $E = 200 \text{ GPa}$, $\rho = 7840 \text{ kg/m}^3$, $A = 240 \text{ mm}^2$.



Fig.Q10(b)

(10 Marks)
