

--	--	--	--	--	--	--	--	--	--

**Sixth Semester B.E. Degree Examination, June/July 2019**  
**Design of Machine Elements – II**

Time: 3 hrs.

Max. Marks:100

- Note: 1. Answer any FIVE full questions, selecting at least TWO questions from each part.**  
**2. Missing data may be suitably assumed.**  
**3. Use of data handbook is permitted.**

**PART – A**

- 1 a. Determine the value of 'b<sub>1</sub>' of a unsymmetrical I-beam cross-section of a curved beam shown in Fig.Q1(a) such that the extreme fibre stresses due bending are numerically equal. (12 Marks)

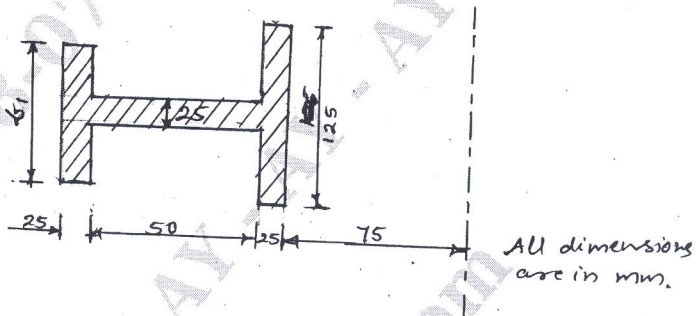

Fig.Q1(a)

- b. A cast iron cylinder of internal diameter 200mm and the thickness 50mm is subjected to a pressure of 5 MPa. Calculate the tangential and radial stresses at inner, middle and outer surface. (08 Marks)
- 2 a. Design a flat belt to drive a compressor by means of an electric motor of 12 kW having a speed ratio of 3. The speed of the motor shaft is 900 rpm. Assume a service factor of 1.5 (10 Marks)
- b. Select a wire rope of an elevator in the building using the following details:  
 (i) Weight of elevator = 30 kN, (ii) Weight of passenger = 12 kN, (iii) Total lift = 250m, (iv) Rope velocity = 5 m/s to be reached in a distance of 10 meters (v) FOS = 7. (10 Marks)
- 3 a. A carriage weighing 25 kN is moving on a track with velocity of 3.6 km/hr. It is brought to rest by two buffer springs in which the maximum compression is 180 mm. The permissible shear stress in spring material is 450 MPa. Design the spring of index 6 and modulus of rigidity as 81.4 GPa. (12 Marks)
- b. A laminated spring for truck has an effective length of 1 m and central load of 10 kN is undergoes deflection of 75 mm. The spring has 10 leaves, two of which are full length and have been pre-stressed so that all leaves have same stress of 350 MPa. Calculate the width and thickness of the leaves. (08 Marks)
- 4 a. Derive the Lewis equation for the beam strength of a gear tooth. (04 Marks)
- b. Design a pair of spur gears to transmit 25 kW of power at a pinion speed 1000 rpm for the velocity ratio is 2.5 : 1. The centre to centre distance of shaft to be about 300 mm. The static design stress for pinion and gear are 200 MPa and 180 MPa respectively. Considering class-II gear with 20° full depth involute tooth. The material for pinion is steel (BHN = 250) and gear is cast iron (BHN = 200). (16 Marks)

Important Note : 1. On completing your answers, compulsorily draw diagonal cross lines on the remaining blank pages.  
 2. Any revealing of identification, appeal to evaluator and /or equations written eg. 42+8 = 50, will be treated as malpractice.

**PART – B**

- 5 A pair of straight bevel gears are to transmit 15 kW at 1500 rpm input speed. The number of teeth on pinion is 20 and the speed ratio is 5. Design the gears assuming  $14\frac{1}{2}$  full depth form. (20 Marks)
- 6 a. Design a cone clutch to transmit 40 kW at 750 rpm. Assume  $f = 0.4$ ,  $p = 0.2$  MPa,  $\alpha = 12.5^\circ$ ,  $D_m/b = 6$ . (10 Marks)
- b. A simple band brake as shown in Fig.Q6(b) is to be designed to absorb power of 30 kW at a rated speed of 750 rpm. Determine
- The effort required to stop clockwise and anticlockwise rotation of the brake drum.
  - The dimensions of rectangular c/s of the brake lever assuming its depth to be twice the width.
  - The dimensions of the c/s of the band assuming its width to be ten times the thickness. (10 Marks)

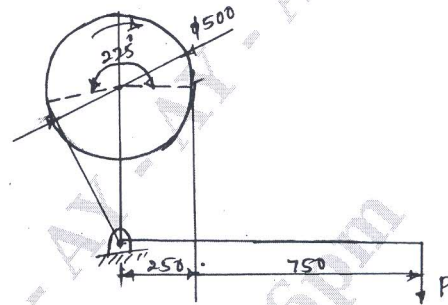

Fig.Q6(b) : All dimensions are in mm

- 7 a. Derive Petroff's equation, with usual notations. (06 Marks)
- b. Design a journal bearing for a centrifugal pump running at 1200 rpm. Diameter of journal is 100 mm and load on bearing is 15 kN. Take  $l/d = 1.5$ , bearing temperature  $50^\circ$  and ambient temperature is  $30^\circ$ . Find whether artificial cooling is required. (14 Marks)
- 8 Design a cast iron piston for a single acting four stroke diesel engine with the following data : Cylinder bore = 200 mm, length of stroke = 250 mm, Speed = 600 rpm, Brake mean effective pressure = 0.6 MPa. Maximum gas pressure = 4 MPa. Fuel consumption = 0.25 kg per BP per hour. (20 Marks)

\* \* \* \* \*