



USN

--	--	--	--	--	--	--	--	--	--

**Fourth Semester B.E Degree Examination, June 2019
(AE/AS)**

COMPUTER AIDED AIRCRAFT DRAWING

Time:3 Hours

Max. Marks:100

Note:

1. Answer any one question from each of parts A,B and C
2. Use First angle projection only
3. Missing data if any may suitable may assumed
4. All the calculation should be on answer sheet supplied
5. All the dimensions are in mm
6. Part C assembled view should be in 3D and other 2 views in 2D

Part-A

1. A pentagonal pyramid of 20mm edge of base and 40mm high stands vertically with its base on HP and an edge of the base perpendicular to VP. A section plane perpendicular to HP and inclined 30° to VP cuts the pyramid such that it passes through the pyramid at a shortest distance of 5mm from its axis and in front of it. Draw its sectional front view and true shape of section. 20 marks
2. For the object shown below draw the three views. Show all the dimensions. 20 marks

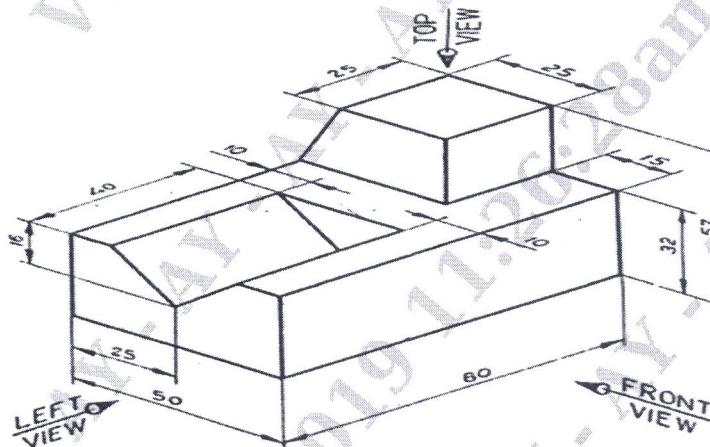

Part-B

3. Draw two views of hexagonal headed bolt with nut for a 20mm dia bolt. Take length of bolt 100mm. 20 marks
4. Draw neat sketch of ISO thread profile of pitch 50mm. Indicate all dimensions. 20 marks

Part-C

5. The details of WING ASSEMBLY are shown in fig1. Draw front, top and left views of the assembly. 60 marks

6. The details of a ENGINE MOUNT ASSEMBLY are shown in fig2. Draw front, top and left views of the assembly. 60 marks

Assembly of Centre wing

Item Number	Title	Material	Quantity
1	Wing Skin	Aluminum Alloy	1
2	Spar Front	Aluminum Alloy	1
3	Spar Rear	Aluminum Alloy	1
4	Rib	Aluminum Alloy	2

DATE	BY	CHKD	APP'D

FILE	DATE	DESCRIPTION

SOLID EDGE
 ©2005 The PDM Company
 FILE: F:\SOLID EDGE\...
 USER: ...
 DATE: ...

Airfoil Co-ordinate Details-2412

X	Y	Z
1	0	0.0013
0.95	0	0.0114
0.8	0	0.0375
0.6	0	0.0636
0.4	0	0.078
0.25	0	0.0767
0.15	0	0.0661
0.075	0	0.0496
0.025	0	0.0299
0	0	0
0.025	0	-0.0227
0.075	0	-0.0346
0.15	0	-0.041
0.25	0	-0.0422
0.4	0	-0.038
0.6	0	-0.0276
0.8	0	-0.015
0.95	0	-0.0048
1	0	-0.0013

Item Number	Title	Material	Quantity
1	Wing Skin	Aluminum Alloy	1
2	Spar Front	Aluminum Alloy	1
3	Spar Rear	Aluminum Alloy	1
4	Rib	Aluminum Alloy	2

Fig 1

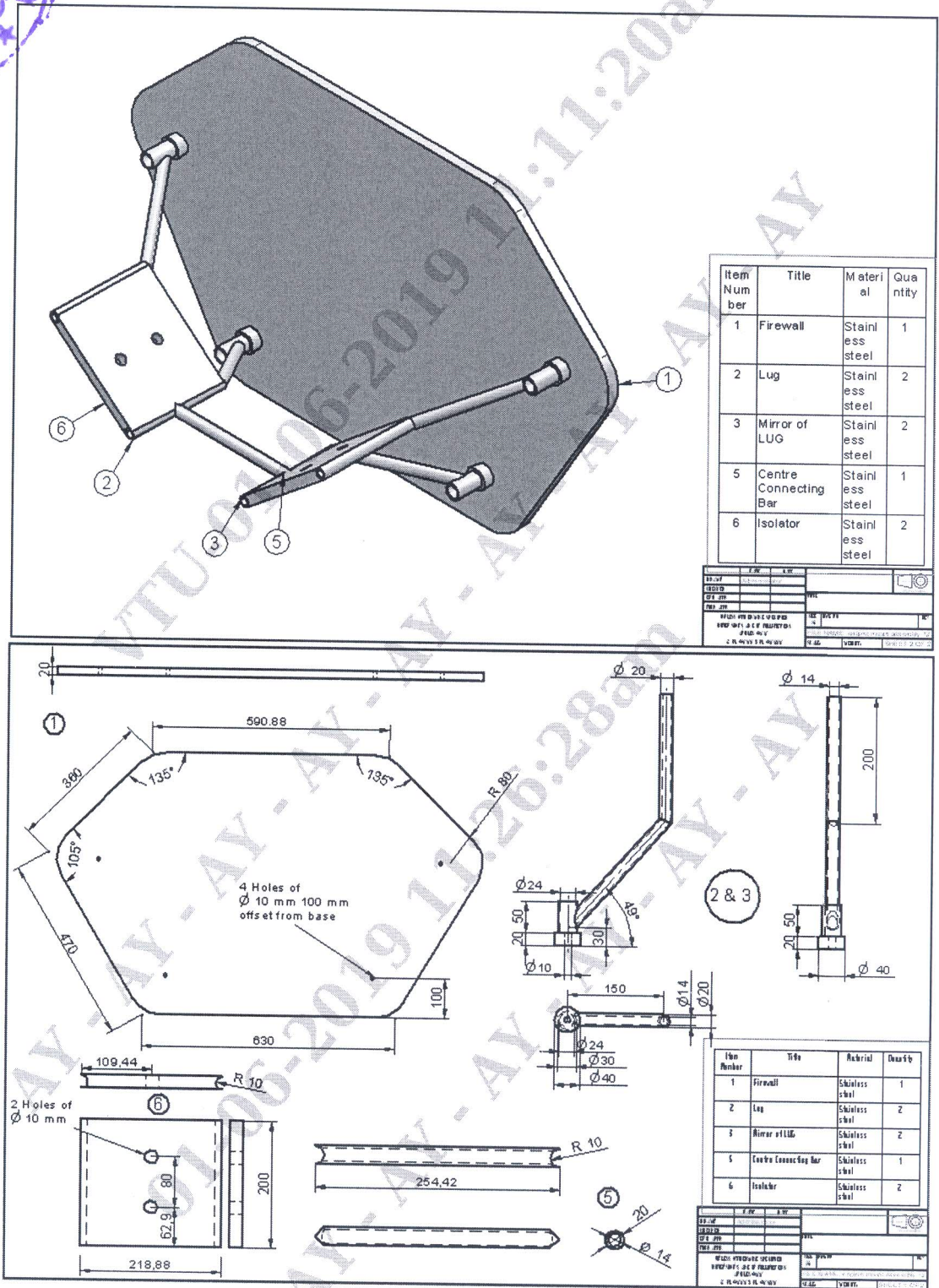

Fig 2.