

--	--	--	--	--	--	--	--	--	--

Sixth Semester B.E. Degree Examination, Dec.2018/Jan.2019 Design of Machine Elements – II

Time: 3 hrs.

Max. Marks: 80

*Note: 1. Answer any FIVE full questions, choosing one full question from each module.
2. Use of hand book is permitted.*

Module-1

- 1 a. List the assumptions made in obtaining stress equation in curved beam. (06 Marks)
- b. Compute the combined stresses at the inner and outer fiber in the critical cross-section of a crane hook which is required to lift loads upto 25 kN. The hook has trapezoidal cross section with the parallel sides 60mm and 30mm. The distance between them being 90mm. The inner radius of hook is 100 mm. The load line is nearer to the inner surface of the hook by 25 mm than the centre of curvature at the critical section. What will be the stresses at inner and outer fiber, if the beam is treated as straight beam for given load? (10 Marks)

OR

- 2 a. A cast iron cylindrical pipe of outside diameter 300mm and inside diameter 200mm is subjected to an internal pressure of 20 MPa and external pressure of 5 MPa. Determine the tangential and radial stresses at inner, middle and outer surface. Also sketch the stresses distribution across the thickness. (08 Marks)
- b. A 440 mm outer diameter, 250mm inner diameter and 300mm long steel hub is to be shrink on to a 250mm diameter steel shaft. If the torque is to be transmitted is 300 kNm and $\mu = 0.18$, determine the amount of interference required. (08 Marks)

Module-2

- 3 a. A belt is required to transmit 18.5 kW from a pulley of 1.2m diameter running at 250 rpm to another pulley which run at 500 rpm. The distance between the centres of pulley is 2.7m. The following data refers to open belt drive $\mu = 0.25$. Safe working stress for leather is 1.75 MPa. Thickness of belt 10 mm. Determine the width and length of belt taking centrifugal tension into account. Also find the initial tension in belt and speed at which this can be transmitted. (08 Marks)
- b. A V-belt is to transmit 20 kW from a 250 mm pitch diameter operating at 1500 rpm to a 900 mm diameter flat pulley. The centre distance between input and output shaft 1 m. The groove angle is 40° and $\mu = 0.2$ for both pulleys and shears combination. The cross section of belt is 38mm wide at the top and 19mm at bottom by 25mm deep. Each belt weighs 11 kN/m^3 and allowable tension per belt is 1000 N. How many belts are required? (08 Marks)

OR

- 4 a. A loaded narrow gauge car weighs 18 kN and moving at a velocity of 80 m/min is brought to rest by a buffer spring of two helical springs. In bringing the car to rest the spring undergoes a compression of 200mm. The allowable shear stress is 0.3 GPa and spring index is 8. Solve for the dimensions of spring. Take $G = 84 \text{ GPa}$. (08 Marks)
- b. A semi-elliptical leaf spring is used for the suspension of the rear axle of a truck. It consists of 2 extra full length leaves and IS graduated leaves with a band of 100 mm. The centre to centre distance between spring eyes is 1.1 m. All leaves are pre-stressed to 400 MPa. $E = 200 \text{ GPa}$. The max. force on spring is 75 kN. Take total depth to width ratio as 2. Determine (i) Cross section of leaf (ii) Initial nip (iii) Load on band. (08 Marks)

Module-3

- 5 Design a pair of spur gear 20° involute to transmit 30 kW of power at 600 rpm of pinion. Number of teeth on pinion is 15, transmission ratio is 5:1. Material of the pinion is cast steel ($\sigma = 137.34$ MPa) and that of gear is high grade cast iron ($\sigma = 103$ MPa.). (16 Marks)

OR

- 6 a. Derive an equation for formative number of teeth on bevel gear. (06 Marks)
 b. Determine the module for a pair of helical gear to transmit 15 kW of power at 4000 rpm of pinion with $i = 5:1$. Pinion is made of 0.4% carbon steel untreated ($\sigma = 69.6$ MPa) and gear is made of cast iron ($\sigma = 31$ MPa). Helix angle is 20° . Number of gear teeth on pinion is 24. (Gear system 20° FDI). (10 Marks)

Module-4

- 7 Design worm drive to transmit a power of 2 kW at 1000 rpm, $i = 20:1$ and centre distance is 200 mm. (16 Marks)

OR

- 8 a. Design a multi-plate clutch to transmit 25 kW at 300 rpm. The plates have friction surfaces of steel and phosphorous bronze run on oil. Design clutch for 25% over load. (08 Marks)
 b. A simple band brake is required to transmit a torque of 100 kg-m. The brake drum diameter is 400 mm, $\mu = 0.25$. Find the effort required to obtain braking in clock-wise direction. Design the band and the lever. Take $\theta = 270^\circ$. [Refer Fig.Q8(b)] (08 Marks)

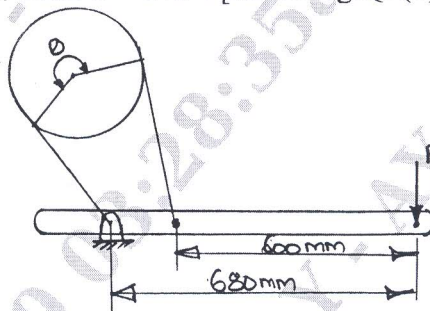

Fig.Q8(b)

Module-5

- 9 a. Derive Petroff's equation for lightly loaded bearing. (06 Marks)
 b. A lightly loaded journal bearing has a load of 1 kN. The oil used is SAE60 and mean effective temperature of operation is 40°C . The journal has a diameter of 50 mm and the bearing has a diameter of 50.5mm. The speed of journal is 15000 rpm. The L/d ratio is limited to 1.2. Determine CoF and power loss in friction. (10 Marks)

OR

- 10 a. Explain the principle of Hydro Dynamic lubrication. (06 Marks)
 b. A spindle of a wood-working machine runs at 1000 rpm. It is mounted on two single-row ball bearings. One of which is required to carry radial load of 2250 N and thrust load of 1900 N. The machine runs 8 hrs/day. Assuming a life of 4 years a spindle diameter equal to 30 mm. Select a suitable bearing. (10 Marks)
