

CBCS Scheme

USN

T A Y I S M E O I O

15ME54

Fifth Semester B.E. Degree Examination, Dec.2017/Jan.2018

Design of Machine Elements – I

Time: 3 hrs.

Max. Marks: 80

- Note: 1. Answer any FIVE full questions, choosing one full question from each module.
 2. Use of design data hand book is allowed.
 3. Assume suitable missing data.*

Module-1

- 1 a. Define standards and codes. (04 Marks)
 b. A circular rod of diameter 50 mm is subjected to loads as shown in Fig.Q1(b). Determine the nature and magnitude of stresses at the critical points.

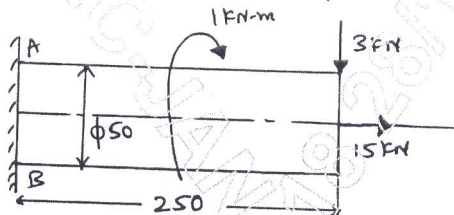

Fig.Q1(b) (12 Marks)

OR

- 2 a. Briefly explain the phases of design process (Shigley's). (04 Marks)
 b. A flat bar shown in Fig.Q2(b) is subjected to an axial load of 100 kN. Assuming that the stress in the bar is limited to 200 N/mm², determine the thickness of bar.

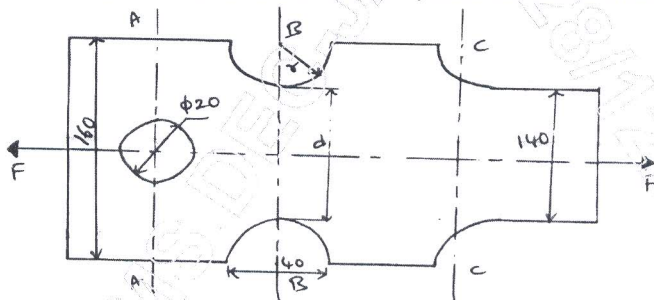

Fig.Q2(b) (12 Marks)

Module-2

- 3 a. A cantilever beam of span 800 mm has a rectangular cross section of depth 200 mm. The free end of the beam is subjected to a transverse load of 1 kN that drops on to it from a height of 40 mm. Selecting C40 steel ($\sigma_y = 328.6$ MPa) and FoS = 3; determine the width of rectangular cross section.

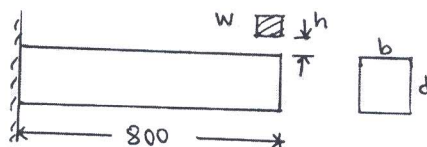

Fig.Q3(a) (08 Marks)

- b. A rectangular cross section bar 200 mm long is subjected to an impact by a load of 1 kN that falls on to it from a height of 10 mm from rest. Determine the cross section dimension of rectangular bar, if the allowable stress of material of bar is 125 N/mm². Assume the thickness depth is twice width. Also find the deformation due to impact. (08 Marks)

Important Note : 1. On completing your answers, compulsorily draw diagonal cross lines on the remaining blank pages.
 2. Any revealing of identification, appeal to evaluator and /or equations written eg, 42+8 = 50, will be treated as malpractice.

OR

- 4 A round rod of diameter $1.2d$ is reduced to a diameter ' d ' with a fillet radius of $0.1d$. This stepped rod is to sustain a twisting moment that fluctuates between $2.5 \text{ kN}\cdot\text{m}$ to $1.5 \text{ kN}\cdot\text{m}$ together with a bending moment of $+1 \text{ kN}\cdot\text{m}$ to $-1 \text{ kN}\cdot\text{m}$. The rod is made of carbon steel C40 ($\sigma_y = 328.6 \text{ MPa}$; $\sigma_u = 620 \text{ MPa}$). Determine suitable value for ' d '. (16 Marks)

Module-3

- 5 A solid steel shaft running at 600 rpm is supported on bearings 600 mm apart. The shaft receives 40 kW through a 400 mm diameter pulley weighing 400 N located 300 mm to the right of left bearing by a vertical flat belt drive. The power is transmitted from the shaft through another pulley of diameter 600 mm weighting 600 N located 200 mm to the right of right bearing. The belt drives are at right angles to each other and ratio of belt tension is 3. Determine the size of shaft necessary, if the allowable shear stress in the shaft material is 40 MPa and the loads are steady. (16 Marks)

OR

- 6 Design a flange coupling to connect the shafts of a motor and centrifugal pump for the following specifications: Pump output = $3000 \text{ liters/minute}$, total head = 20 m , pump speed = 600 rpm , pump efficiency = 70% . Select C40 steel ($\sigma_y = 328.6 \text{ MPa}$) for shaft and C35 steel ($\sigma_y = 304 \text{ MPa}$) for bolts with factor of safety 2. Use allowable shear stress in cast iron flanges equal to 15 N/mm^2 . (16 Marks)

Module-4

- 7 a. A double riveted lap joint is to be made between 9 mm plates. If the safe working stresses in tension, crushing and shear are $80, 120$ and 60 N/mm^2 respectively, design the riveted joint. (08 Marks)
- b. Determine the diameter of rivet for the joint shown in Fig.Q7(b). The allowable stress in the rivet is 100 N/mm^2 .

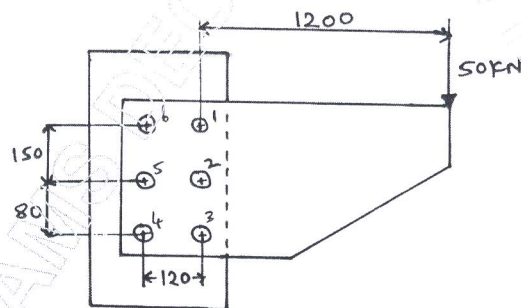

Fig.Q7(b)

(08 Marks)

OR

- 8 a. A 16 mm thick plate is welded to a vertical support by two fillet welds as shown in Fig.Q8(a). Determine the size of weld, if the permissible shear stress for the weld material is 75 MPa .

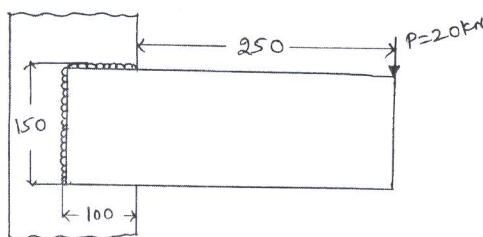

Fig.Q8(a)

(08 Marks)

- b. Determine the allowable stress in the joint shown in Fig.Q8(b), if size of weld is 10 mm.

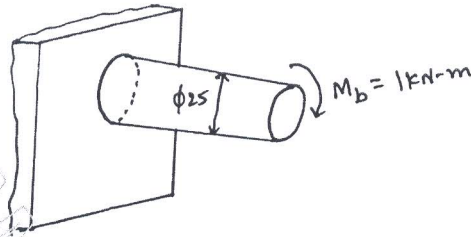

Fig.Q8(b) (08 Marks)

Module-5

- 9 a. The structure in Fig.Q9(a) is subjected to eccentric load $P = 10 \text{ kN}$ with eccentricity of 500 mm. All bolts are identical made of carbon steel having yield strength in tension is 400 MPa and factor of safety is 2.5. Determine size of bolt.

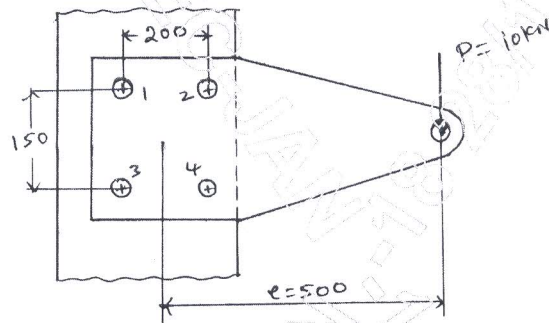

Fig.Q9(a) (08 Marks)

- b. A bracket is fixed to wall by 4 bolts and loaded as shown in Fig.Q9(b). Calculate the size of bolts if the load is 10 kN and allowable shear stress in bolt material is 40 MPa.

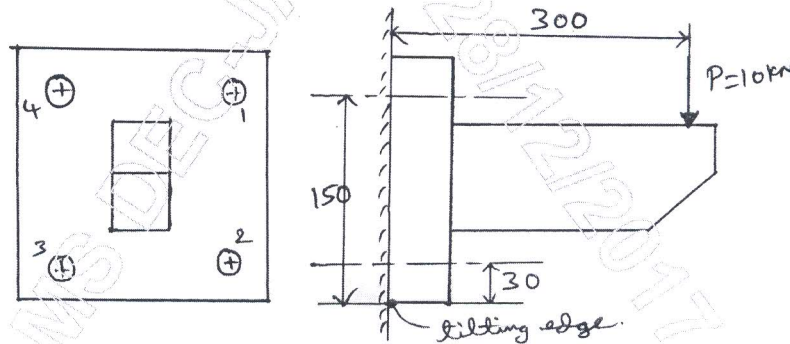

Fig.Q9(b) (08 Marks)

OR

- 10 Design a Screw Jack (complete design) with a lift of 300 mm to lift a load of 50 kN. Select C40 steel ($\sigma_y = 328.6 \text{ MPa}$) for the screw and soft phosphor bronze ($\sigma_{ut} = 345 \text{ MPa}$ and $\sigma_v = 138 \text{ MPa}$) for nut. (16 Marks)
